

DESIGN MANUAL

Model GT811 Toxic Gas NOVA-Sensor

70018

The information and technical data disclosed by this document may be used and disseminated only for the purposes and to the extent specifically authorized by SAFETY SYSTEMS TECHNOLOGY in writing. Such information and technical data are proprietary to SAFETY SYSTEMS TECHNOLOGY and may not be used or disseminated except as provided in the foregoing sentence.

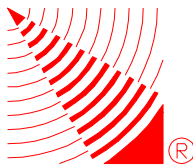

SAFETY SYSTEMS TECHNOLOGY

23282 Mill Creek Drive, Suite 215

Laguna Hills, California 92652

Phone 1-949-583-1857 Fax 1-949-340-6643

www.safetysys.com

Quick Finder - Model GT811 NOVA-Sensor

MODEL GT811 TOXIC GAS NOVA-Sensor

QUICK START	811-1
Apply Power	811-1
Operation	811-1
Calibration	811-1
Alarm Points	811-1
DIP Switch: Latch / No Latch LOW Alarm	811-1
DESCRIPTION	811-2
Variants	811-2
TECHNICAL SPECIFICATIONS	811-3
INSTALLATION	811-4
The GT811 Unit	811-4
Installation Sequence	811-4
Mounting the enclosure	811-4
Wiring	811-5
DIP Switch Settings	811-7
Remote Sensor Version	811-8
OPERATION	811-10
Power-Up	811-10
Non-Volatile Memory	811-10
Changing the Setpoints	811-10
Calibration	811-10
SYSTEM OUTPUTS	811-12
4-20 mA Current Loop	811-12
Relay Outputs	811-12
EIA-485 (M-LAN™)	811-14
FINAL OPERATIONAL CHECK-OUT (CompTest™)	811-14
How to Start the CompTest	811-14
Entering the Safety-Code™	811-15
CompTest™ Operational Sequence	811-16
MAINTENANCE	811-16
Recalibration Schedule	811-17
Sensor Replacement	811-17
Electronics Module Replacement	811-17
Spare Parts	811-17
TROUBLESHOOTING	811-18
Wiring of the CHASSIS Terminal	811-18

LOW-POWER VERSION

Operation of the Low-Power Version	811-19
------------------------------------	--------

RECALIBRATING THE SENSOR HEAD

Calibration Gas	811-20
Calibration Instructions	811-20

MODEL GT811 TOXIC GAS NOVA-Sensor

QUICK START

Apply Power

Apply +24 volts DC to the labeled terminals (+24V, 24V RET).

Operation

Normal operation begins after a 30 second countdown is displayed. The firmware revision (e.g. "1.14") is displayed briefly at the end of the 30 second countdown. The decimal points will flash while the unit displays "000" to confirm to the user that unit is properly functioning. If "000" is not displayed, and there is no background gas, the sensor requires initial calibration.

Calibration

Calibration requires 50% test gas (i.e. 50% of the 10 PPM, 20 PPM, 50 PPM, 100 PPM or 200 PPM range). Insure that zero gas is present before initiating calibration. Press the large MODE button on the outside of the sensor housing for 5 to 10 seconds. The sensor flashes "000" while sampling the zero gas condition (10 seconds). Apply calibration gas when the "000" stops flashing. "CAL" will be flashed as the gas is sampled. When finished (approx. 40 seconds), the display will stop flashing - remove the gas now. The sensor begins normal operation once the gas level is safely below the LOW alarm point.

Alarm Points

Setting

Remove housing cover to access buttons labeled "UP" and "DOWN". Press the large externally mounted MODE button for 1 second. The LOW alarm LED will light as the set point is displayed. Use the UP/DOWN button to alter the value. After 5 seconds, the HIGH alarm LED and set point are displayed, after 5 seconds of button inactivity, the sensor will return to normal operation.

Confirming

To confirm or inspect the alarm set points without declassifying the area, simply press the large external MODE button for 1 second. Each alarm setting will be displayed for 5 seconds.

DIP Switch: Latch / No Latch LOW Alarm

Switch 4 of the 4 position DIP switch in the UP (Open) position selects LATCHING mode for the LOW alarm. Placing the switch DOWN (Closed) configures the LOW alarm as NON-LATCHING.

Power must be cycled to "read" the new DIP setting. Note: the HIGH Alarm is always latched due to code requirements. Switches 1, 2, and 3 are set at the factory per table shown on page 811-8 - DO NOT change setting!

DESCRIPTION

The SST Model GT811 Toxic Gas NOVA-Sensor is a completely self-contained device that measures and displays the concentration of gas accumulated in a protected area, performs local control functions, and optionally transmits this information to a central control point.

The SST sensors use the electrochemical fuel cell method of gas detection. Located inside a stainless steel housing, the sensing element is exposed to the detected gas through a diffusion barrier and gas permeable membrane. A reaction takes place at the working electrode (anode), releasing electrons which flow to the counter electrode (cathode), where a counter reaction occurs. These reactions may or may not consume the electrolyte; the SST cell is typical of cells which do not consume electrolyte. It reacts as follows:

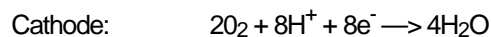
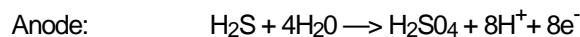

This flow of electrons is measured as a concentration value by the SST NOVA-Sensor electronics.

Each SST NOVA-Sensor includes a high reliability microcontroller based transmitter/controller in the associated explosion proof junction box. A digital read-out is provided to continuously display operating status and the actual concentration of gas present in (PPM) parts per million. The transmitter converts this reading and generates a standard 4-20 mA signal. This signal may be connected to a suitable SST NOVA-5000 Gas Detection Module, or to any other device with a standard 4-20 mA input. Connections between the transmitter and control device are normally made with 3 conductor cable [+24 VDC, 24 V return, 4-20 mA signal]. Relays are provided for LOW Gas Alarm, HIGH Gas Alarm, and Fault. The low and high relays operate at user adjustable alarm set points; the fault relay operates upon loss of power or internal failure of the unit. Relays are suitable for controlling local HVAC or equipment shutdown. An optional RS-485 interface is also available.

The Model GT811 is suitable for the most demanding applications. A large body mass insures excellent vibrational characteristics when used offshore. Corrosion resistant materials permit uses in extreme environments.

Variants

The SST Model GT811 Toxic Gas NOVA-Sensor comes in the following variations:

- Toxic Gas Detector with 10 PPM, 20 PPM, 50 PPM, 100 PPM, or 200 PPM full scale range for various toxic gases
- Standard power consumption version, Low-power version

This manual applies to the standard power consumption version of the SST Model GT811 Toxic Gas NOVA-Sensor. Technical specifications and operation of the low-power version

of the GT811 is slightly different from those of the standard GT811. Details on the variants are listed in the section "Low-Power Version" at the end of this manual.

TECHNICAL SPECIFICATIONS

Power Supply (standard version)	.24 volts DC nominal, 80 mA standby, 140 mA when in alarm. Will operate within specifications at any supply voltage between 16 and 32 volts.
Power Supply (low-power version)	.24 volts DC nominal, 50 mA standby (display off), 75mA standby (display on), 140 mA when in alarm. Will operate within specifications at any supply voltage between 16 and 32 volts.
Response time20 Seconds - SO ₂ 35 Seconds - CO 60 Seconds - H ₂ S 90 Seconds - CL ₂ or NH ₃ Maximum time required to reach 90% of the final measured concentration.
Operating Temperature	-.40 to +131° F. -40 to +55° C (H ₂ S, SO ₂) +23 to +131° F. -5 to +55° C (CO) - 13 to +131° F. -25 to +55° C (NH ₃) +5 to +131° F. -15 to +55° C (CL ₂) May be operated intermittently up to 150° F.
Operating Humidity	Relative Humidity 0-100% non condensing
Sensitivity16 mA/full scale output per PPM. Automatically adjusted during calibration
AccuracyLinear response between 0 and full scale. Output drift less than 2% of full scale per month.
Relay Contact Ratings6 amps @ 28 VDC resistive 6 amps @ 300 VAC resistive 1/8 HP @ 120/240 VAC
Analog OutputSensor will source 0-20 mA DC into a load of 600 ohms or less.
Optional Digital OutputDesigned per EIA-485 to permit bi-directional communication between detectors and data acquisition system over shielded twisted pairs.

INSTALLATION

The GT811 Unit

A complete GT811 unit consists of the following components:

- explosion-proof housing with MODE button, toxic sensor head, terminal blocks for field wiring and transparent lid used to observe the operational status of the numerical readouts and LED's.
- electronics module consisting of a stack of 5 round printed circuit boards.

The field wiring is connected to the terminal blocks on the bottom of the enclosure. The terminal blocks are accessible after removing the enclosure lid and the electronics module.

The face plate (topmost printed circuit board) of the electronics module carries various displays and controls. These are:

- Three-digit seven-segment LED display (numerical readout) for the display of gas concentration and status.
- Four round LED's, labeled "FAULT" (yellow), "HIGH" (red), "LOW" (red) and "CAL" (green). These LED's are used to signalize alarms and operating modes.
- Two square pushbutton switches, labeled "UP" and "DOWN". These switches are accessible with a small screw driver or ball point pen and can be used to adjust the alarm setpoints of the unit.

Installation Sequence

The electronics module contains parts that are delicate and potentially sensitive to electrostatic discharge (ESD). Thus, the electronics module should be plugged into the terminal blocks in the enclosure right before system start-up, after all drilling and wiring is completed. The recommended installation procedure is as follows:

- Mounting the enclosure
- Wiring of power and signal cables, and, if required, of remote sensor
- Setting the DIP switches and suitcase jumpers on the electronics module
- Checking the field wiring, plugging in the electronics module
- Applying 24VDC power
- Setting the alarm setpoints, if required
- Calibration and functional check out with CompTest, if required

Mounting the enclosure

The dimensional characteristics of the GT811 unit are shown in figure 811-1. It is preferable to attach the sensor to a wall or bracket, using bolts through the two mounting holes. However, these mountings may be omitted if the electrical conduit is sufficiently rigid to support the weight of the detector.

The location of the sensor is important. For lighter than air gasses, such as Ammonia, the sensor should be located **above** the spot where a leak is likely. For heavier than air gasses, such as Hydrogen Sulfide, locate the sensor **below** the expected leak. However, do not locate the sensors closer than 1 foot to a floor to prevent damage from water, dust, etc.

Preferred orientation of the sensor is with the screen pointing down, as shown in the figure. If necessary, it may be installed at an angle or horizontally. The sensor must *never be installed pointing upwards*.

Remote Sensor Mounting Version

The standard Model GC811 NOVA-Sensor is shipped with the sensor preinstalled onto the electronics housing. A special version, SST order number 811-11, is used if the gas sensor is located in an inaccessible location. The wiring for the remote sensor is described in the section “Remote Sensor Version” at the end of these installation instructions.

Wiring

Sensor Input

The sensor head is pre-wired to the NOVA-Sensor electronics by SST at the factory. In cases where the sensor is removed from the NOVA-Sensor housing and mounted remotely, you must provide wiring between the electronics and the housing. The color code of the sensor wires connected to the terminal block varies, depending on the type

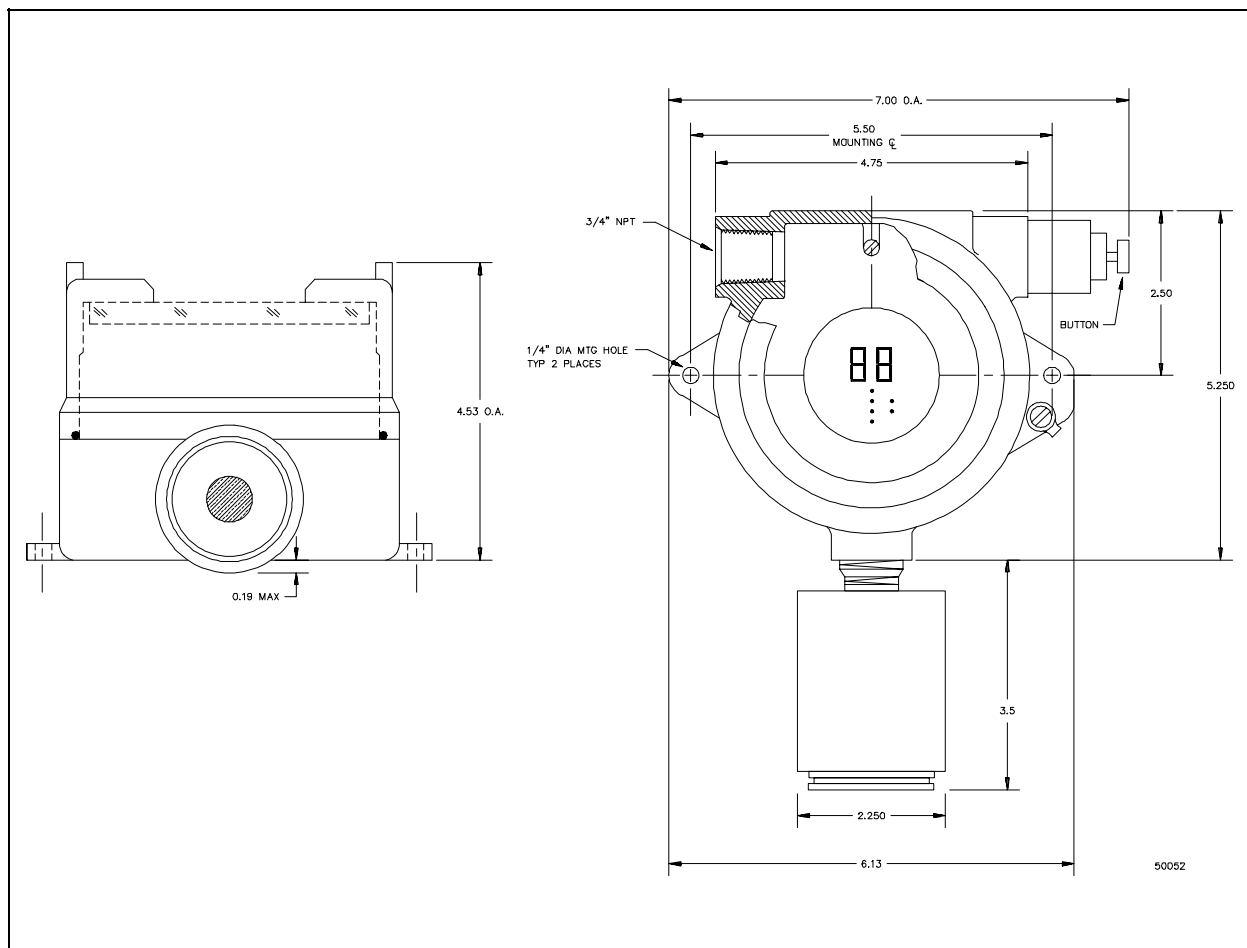

Figure 811-1 Mounting Dimensions

of sensor. Carefully note the color of wire connected to the terminals S, 01 and NS (if used). Install the remote sensor, and be sure that the colored wires connect to the proper terminals. These wires should be at least #16 AWG or 1.0 mm² and must be shielded or installed in shielded conduit.

Power Input and Analog Signal Output

A typical installation is shown in figure 811-3. This setup uses three wires between the NOVA-Sensor and the associated control modules. These wires carry the 24 VDC operating power for the sensor, and transmit the 20 mA signal to the controls. The wires should be shielded or installed in metal conduit to prevent undesirable noise pickup. To wire the NOVA-Sensor, carefully remove the electronics module from the housing by pulling upward. Connect the three wires to the screw terminals in the housing. The terminals are marked as follows:

- +24 V +24 volts DC power input
- 24V RET Common return for DC power and 4-20 mA signal
- 4-20 mA Analog signal source to control equipment

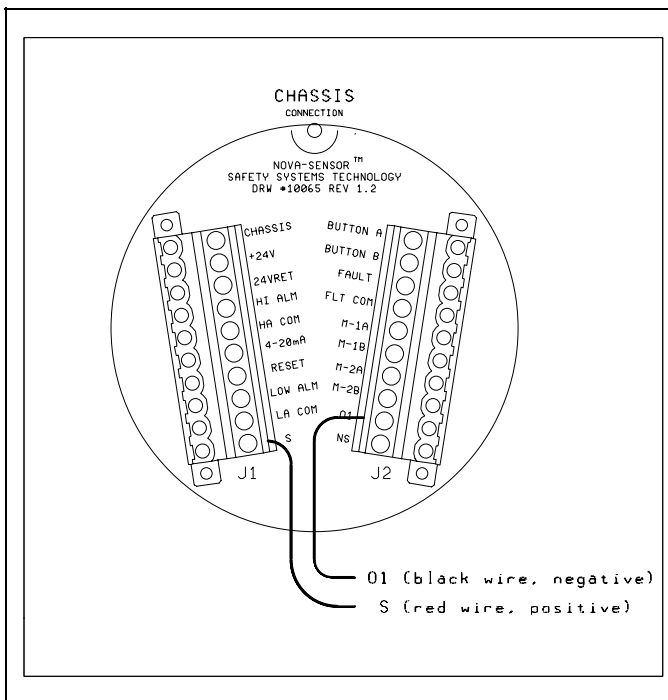

Figure 811-2 Sensor head color codes

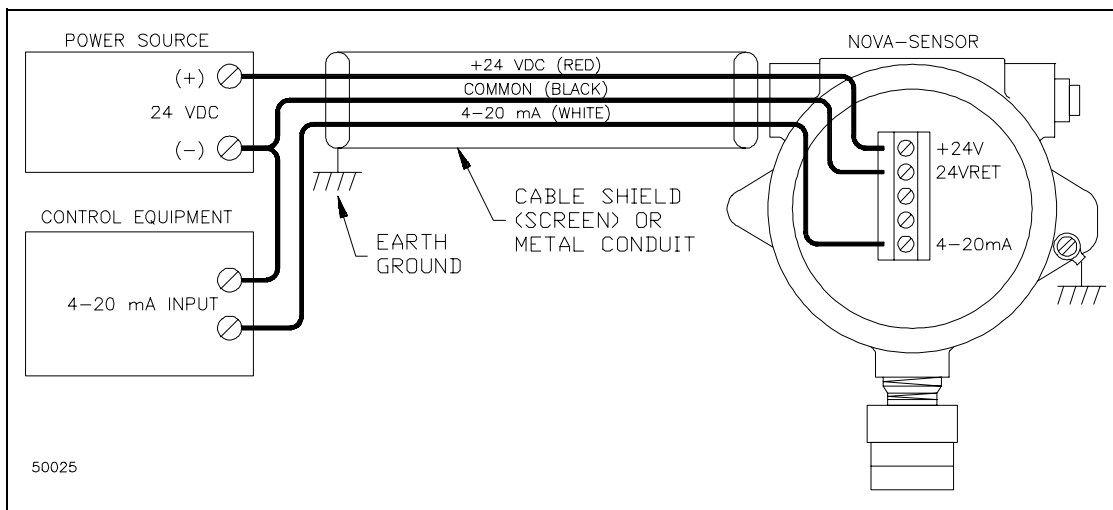

Figure 811-3 Sensor Output Wiring

MODE Pushbutton and Remote RESET

The integral, external MODE push-button on the NOVA-Sensor housing can be used to clear any relays or alarms in the NOVA-Sensor which have been latched when activated. Pressing the button for less than 3 seconds (.5 second minimum) will cause the latched relays to clear and the Alarm setpoints to be momentarily displayed.

An optional external, remotely located, push-button switch can be wired to the terminal marked RESET. This should be a normally open contact, and should connect the reset terminal to 24VRET (COMMON) to reset the sensor, when actuated. The remote RESET button, when active for between .5 and 3 seconds will clear any latched relays.

Electronics Module

The electronics module consists of 4 circuit boards and a faceplate provided as a single replaceable unit. The DIP switches are visible from the side of the module, the suitcase jumpers can be found at the lower board edge. The electronics module contains no user serviceable parts.

Relay Contacts

If the internal alarm and fault relay contacts are being used, additional wiring is required. The terminals for these are marked as follows:

- HIGH ALMHIGH Alarm relay contact
- HA COM Common contact for above
- LOW ALM LOW Alarm relay contact
- LA COM Common contact for above
- FAULT Fault relay contact
- FLT COM Common contact for above

Suitcase jumpers on the lower most circuit board allow relay configuration as normally open or closed.

Factory settings are:

- Alarms: Normally Open (N.O.)
- Fault: Open on Fault (O.F.)

! Two suitcase jumpers are factory installed at the positions marked "TOX". Do not remove these jumpers nor move them to the "C" position.

DIP Switch Settings

The DIP switches are visible from the side of the electronics module. There is a four position DIP switch and optionally a five position switch (EIA-485 option). Separate instructions are provided to users of the EIA-485 option concerning the appropriate settings of the five position switch. When selecting a new DIP switch setting, power must be cycled to "read" the new DIP configuration.

Four position DIP switch

DIP switch position 4 configures the LOW alarm as latching or non-latching. The UP (Open) position selects LATCHING mode for the LOW alarm. Placing the switch DOWN

(Closed) configures the LOW alarm as NON-LATCHING. When latched, the relay will not return to normal until the NOVA-Sensor is manually reset using the MODE button or remote RESET inputs.

Note: the HIGH Alarm is always latched due to code requirements.

The remaining DIP switch positions are set at the factory - **DO NOT adjust these switches!** The factory default settings for these DIP switch positions are:

Product	1	2	3
811-x-200	UP	UP	UP
811-x-100	DOWN	UP	UP
811-x- 50	DOWN	DOWN	UP
811-x- 20	DOWN	UP	DOWN
811-x- 10	UP	DOWN	DOWN
811-x-CUST	UP	UP	DOWN (custom firmware)

! The switch setting must exactly match the sensitivity rating of the sensor head.
You cannot change the sensitivity of a NOVA-Sensor by just changing the switch setting.

Five position DIP switch

The five position DIP switch is mainly used to set the unit address when the NOVA-Sensor is operated with the SST M-LAN (EIA-485 network). Separate instructions are provided to users of the M-LAN concerning the appropriate settings of the five position DIP switch.

The five position switch also serves to select low-power mode for units equipped with the low-power option. The factory default settings for selecting the low-power mode are:

mode	1	2	3	4	5
low-power	UP	UP	UP	UP	UP
standard power	any other combination				

Remote Sensor Version

The standard Model GT811 NOVA-Sensor is shipped with the sensor preinstalled onto the electronics housing. A special version, SST order number 811-11, is used if the gas sensor is located in an inaccessible location. The remote sensor version is the same as a standard version, except that it does not include the sensor head. A SST Model GT810 Toxic Gas Sensor is required for use with the GT811 electronics package. A second 3/4 inch conduit connection is provided to connect the sensor electronics to the remotely located sensor head. Figure 811-4 shows the recommended installation configuration.

Cable considerations

Two conductors are required between the Model GT810 Sensor and the GT811 electronics. These wires will be carrying a maximum of 20 mA at 24 volts DC to provide the required operating current to the loop powered sensor transmitter. In general, the length of cable is not critical, as long as the total resistance of the cable does not exceed 650 ohms.

It is important to specify shielded cable, or to install the wires in metallic conduit. Ground the cable shield to the ground screw in the electronics housing. Excessive noise picked up in the cables can make the display on the NOVA-Sensor jump between various values and can make calibration impossible. This is because the noise makes the NOVA-Sensor believe that the gas values are constantly changing. A constant gas value is the criteria for the end of a calibration.

Cable Color Codes

The GT810 gas sensor head is supplied with two color coded wires which connect to the terminals S and 01 in the GT811 electronics package. These wires are colored Red and Black. If possible, use cable with the same color code to connect between the sensor and the electronics. If different colors are used, be extremely careful to connect each lead to the proper terminal. Interchanging two wires will almost always result in a burned out sensor.

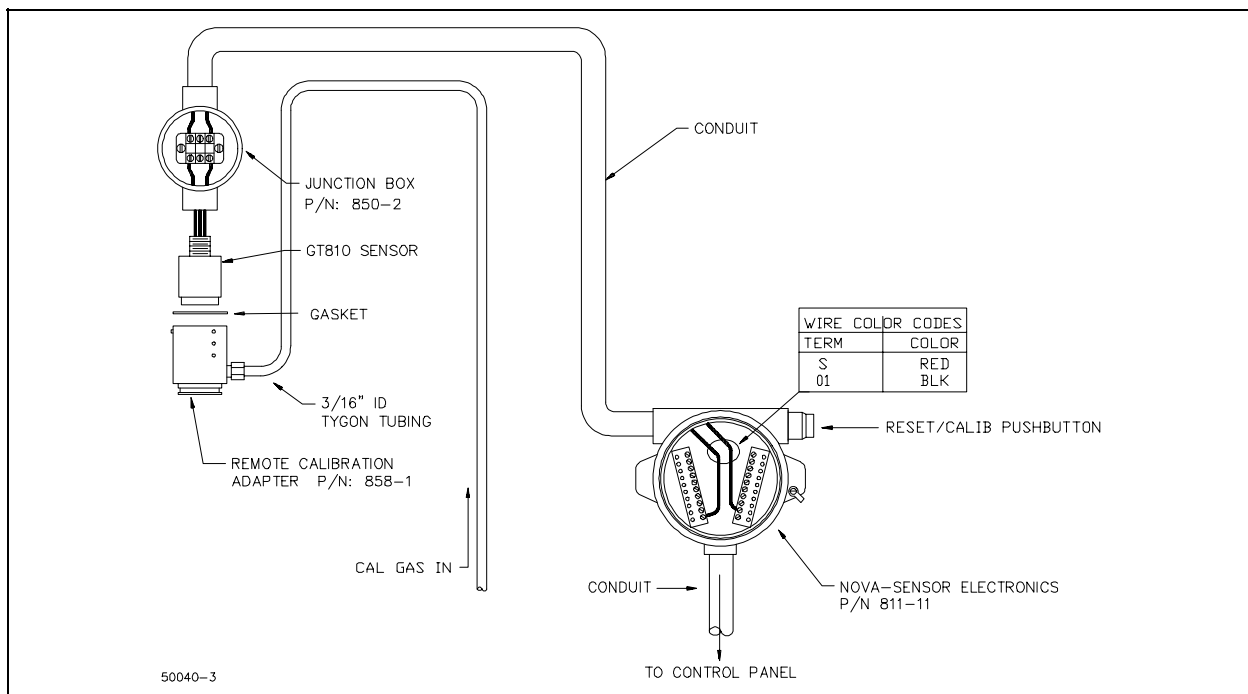

Figure 811-4 Installation with a remote sensor

OPERATION

Power-Up

When power is first applied, the microcontroller executes a built-in test (BIT), during which various internal components and parameters are checked. During the BIT, the indicator lights will be flashing. Upon successful completion of the BIT, the NOVA-Sensor begins a 30 second countdown period to allow time for proper temperature stabilization. The countdown is displayed on the digital read-out. At the end of the countdown, the NOVA-Sensor briefly displays its firmware revision code, e.g. "1.16", and then begins normal **Protective Mode** operation. In protective mode, the digital read-out displays "000". As a further verification that the unit is operating properly, the decimal points on the digital read-out slowly rotate from one digit to the next while displaying 000. The NOVA-Sensor is now operating at the factory default calibration and alarm setpoints. After calibration, the most recent field calibration and alarm setpoint information will be stored in the NOVA-Sensor's non-volatile memory.

Non-Volatile Memory

Calibration data and alarm setpoints are maintained in non-volatile memory to insure proper operation should the +24 VDC supply be temporarily interrupted. No special care is required to maintain this memory.

Changing the Setpoints

Setpoints for HIGH alarm and LOW alarm are available for user modification. Factory defaults for the LOW and HIGH alarms are as follows:

<u>full scale</u>	<u>LOW</u>	<u>HIGH</u>
200	40	100
100	20	50
50	10	25
20	4	10
10	2.0	5.0

The face plate of the electronics module provides two setpoint buttons (UP and DOWN). To adjust either the HIGH or LOW setpoints, press either button. At this point, the LOW alarm LED will turn on, and the LOW alarm setpoint will be displayed. The user has 5 seconds to begin to adjust the LOW Alarm setpoint by pressing the UP or DOWN button. Once the microcontroller has detected 5 seconds of inactivity (no button press), the unit will light the HIGH Alarm LED and display the previously stored setpoint value. The operator will again have 5 seconds to begin adjusting the HIGH alarm setpoint. Setpoint values will roll-over at 10.0, 20, 50, 100, or 200, depending on the full scale. After an additional 5 seconds of inactivity, the NOVA-Sensor will store the new values in non-volatile memory and return to normal operation.

Calibration

The NOVA-Sensor has to be calibrated on installation/commissioning and then later at frequent intervals. Calibration will take care of changes in sensor performance and drift. The automatic calibration procedure provides the NOVA-Sensor with reference points

needed to measure gas levels. During the calibration procedure, clean air, as well as a gas mixture with a defined volume of toxic gas are applied to the detector.

The presence of “clean air”, i.e. air without any toxic components, is absolutely necessary to provide the NOVA-Sensor with a reference point for 0PPM gas concentration. In locations where clean air cannot be assured, you may need to “purge” the sensor with clean air from a gas bottle. DO NOT USE Nitrogen to purge the sensor, false readings may result!

The calibration can be performed by one person, and with the NOVA-Sensor operating in the classified area. No manual adjustments are required for calibration.

NOTE: Calibration gas with a concentration of 50% of the rated full scale of the NOVA-Sensor is required for the calibration procedure (e.g. 50 PPM calibration gas for a 100 PPM sensor).

The calibration procedure is initiated by depressing the large MODE pushbutton located on the side of the enclosure and holding it in for 6 to 10 seconds. The calibration procedure is as follows:

1. The NOVA-Sensor acknowledges that the mode button has been pressed by displaying the current gas concentration (with three steady decimal points) on the digital read-out.
2. Once the MODE button is released, the read-out will flash “**000**” and “...” for about 10 seconds. During this time, the NOVA-Sensor is storing the zero reference point, based on clean air applied to the sensor.
3. The NOVA-Sensor then begins a 15-second countdown, during which it displays the numbers “**030**” to “**000**”. During this time, the NOVA-Sensor is waiting for the calibration gas to be applied and conveyed to the sensor head. NOTE: In order to save gas, it is recommended to apply calibration gas as soon as the 15-second count-down begins.
4. While the gas level at the sensor is quickly ramping up, the readout blinks “**CAL**” for three seconds in turn with the current gas concentration (relative to the previous calibration). Additionally, the “CAL” LED blinks.
5. As the calibration gas at the sensor head reaches saturation level, the readout displays the current gas value every second. This phase lasts 22 seconds.
6. As soon as no more significant changes in the gas concentration are detected, the readout displays the PPM value of the calibration gas (“**100**”, “**050**”, “**025**”, “**010**”, or “**5.0**”, depending on the rated full scale) and stores the calibration gas level as the new reference. At the same time the “CAL” LED changes from blinking to steady. Now the calibration gas should be removed from the sensor.
7. With the calibration gas removed, the readout will decrease, as the residual gas is dissipated. Once the readout is 4 points below the LOW alarm setpoint or at zero, the NOVA-Sensor returns to normal operation and the “CAL” LED is switched off.

The microcontroller in the NOVA-Sensor automatically stores the results of the calibration in its internal non-volatile memory for use in subsequent measurements.

During the calibration process, the 4-20 mA output is set to 2mA and the relay outputs are suppressed.

Failed or Incomplete Calibrations:

If the calibration procedure is aborted (e.g. by not applying calibration gas), the NOVA-Sensor will return to normal operation after a time-out period of 3 1/2 minutes. In this case, the NOVA-Sensor will use its original, pre-calibration data. Turning the 24VDC power off will also abort the calibration procedure. Common causes for incomplete calibration are:

1) Calibration gas runs out during calibration. In this case, wait for the NOVA-Sensor to return to normal operation, and repeat procedure with fresh calibration gas bottle.

2) Calibration gas concentration too low. The NOVA-Sensor will not accept calibration gas with a concentration below 20% of the rated full scale value. Using gas cylinders with low pressure will often be interpreted by the NOVA-Sensor as low gas concentrations. In this case, wait for the NOVA-Sensor to return to normal operation, and repeat procedure with fresh calibration gas bottle.

3) Calibration gas applied at wrong time. Gas applied during step 2 above (i.e. too early, during clean air sampling) will result in negative displays and inaccurate readings. If the gas is applied too late (which may occur due to the pipe length when remote sensors are used) it may not reach significant levels before the 3 1/2 minute time-out.

SYSTEM OUTPUTS

The characteristics of the various NOVA-Sensor outputs are explained in more detail in the following sections.

4-20 mA Current Loop

The 4-20 mA current loop output is normally between 4 and 20 mA, and is a direct linear read-out of gas concentration. Output is 4 mA when no gas being detected. Output is 20 mA when the full scale gas concentration of gas is being detected.

The 4-20 mA circuitry will reliably and accurately (.002% typical nonlinearity) drive a load resistance of between 100 and 800 ohms. The 4-20 mA circuitry is self-calibrating and does not require adjustment.

Should a malfunction occur in the sensor or the current loop wiring, the output will, of course, be 0 mA. During calibration, the output will be 2.0 mA.

Relay Outputs

The NOVA-Sensor includes three (3) relays for connection to external devices. The LOW Alarm and HIGH Alarm relays operated when the concentration of gas measured exceeds the respective setpoints. The fault relay transfers on detection of a fault in the NOVA-Sensor.

Each relay can provide either a normally open or normally closed dry contact output. The **LOW Alarm** and **HIGH Alarm** relay can be set as either **latching** or **non-latching** - see section "DIP Switch Settings". The **Fault Relay** is always **non-latching** (self clearing).

Setting for Normally Open or Normally Closed operation

Three small suitcase jumper plugs located on the lower board of the electronics module determine the sense of the relay contacts. The mating header pins are labeled LO ALM, HI ALM, and FAULT.

When the jumper plug on LO ALM or HI ALM is across the two contacts on the NO side of the header, the respective relay contacts are NORMALLY OPEN. The relay contacts close on alarm.

When the jumper plug on LO ALM or HI ALM is across the two contacts on the NC side of the header, the respective relay contacts are NORMALLY CLOSED. The relay contacts open on alarm.

When the jumper plug on FAULT is across the two contacts on the **OF** side of the header, the relay contacts will **OPEN ON FAULT**. The relay contacts will be closed during normal operation.

When the jumper plug on FAULT is across the two contacts on the **CF** side of the header, the relay contacts will **CLOSE ON FAULT**. The relay contacts will be open during normal operation.

Relay Protection Circuitry

Heavy duty relay contacts are provided in the NOVA-Sensor. These contacts are rated for resistive loads. If used for switching inductive loads, such as relay coils, lamps, beacons, etc., you must provide suitable suppression at the load. This will prevent burning the relay contacts, and also suppress harmful transients which can affect the operation of electronic equipment. Figure 811-5 shows the recommended protection for DC and AC loads.

EIA-485 (M-LAN™)

The **EIA-485** option allows reduced installation costs and increased communications and control between the NOVA-Sensor and the SST NOVA-5000 Detection and Control System. High speed digital communication and control is provided using the Safety Systems M-LAN™ bus protocol. The **EIA-485** communications interface also provides

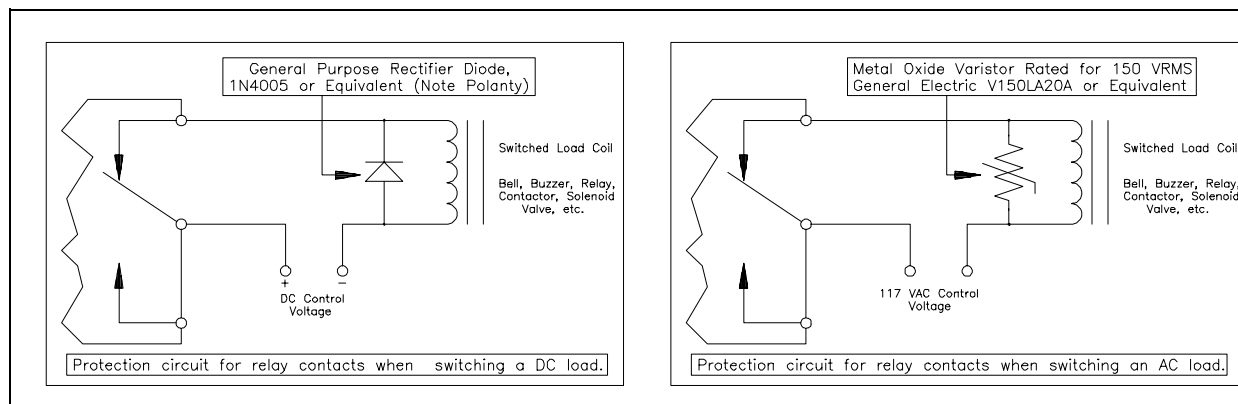

Figure 811-5 Relay Contact Protection Scheme

increased diagnostics and control functions. Reduced installation costs are realized by simplified wiring. All NOVA-Sensors detectors communicate with the central controller via two sets (buses) of twisted pair bus wires. Bus redundancy further increases reliability.

FINAL OPERATIONAL CHECK-OUT (CompTest™)

Once the NOVA-Sensor has entered normal operation, a final comprehensive output test (CompTest) of all detector inputs and outputs is available. The CompTest is a way to verify that the NOVA-Sensor relay outputs and 4-20 mA current loop are correctly operating. It can also be used to determine if the peripheral equipment is properly connected to the NOVA-Sensor.

The **CompTest** ramps the 4-20 mA current loop through each of its assigned values while changing the relay outputs as well. Each output state for the 4-20 mA loop and each of the three relays is held for about 2 seconds and repeated 3 times. The test lasts for approximately 1 minute. At the completion of the test, the built-in test (BIT) is executed and the unit is returned to normal **PROTECTIVE MODE** operation.

What keeps the CompTest from occurring during operation or by mistake?

Because the **CompTest** exercises all outputs, including **LOW ALARM** and **HIGH ALARM** states, there are several built-in safe guards against its inadvertent use. The button located on the side of the NOVA-Sensor (the Mode button) **will not** initiate a CompTest. The remote reset input on the NOVA-Sensor is used to initiate the test, based on a coded sequence of ON's and OFF's. Upon receiving the proper coded input (the CompTest Safety Code), the NOVA-Sensor begins the test. The NOVA-Sensor will only start the Output Tests if the proper Safety Code is entered. For additional security against inadvertent use, the Safety Code can only be entered **during the first 6 minutes** after the NOVA-Sensor has been returned to normal operation. Requiring a special **Safety Code** to be entered within 6 minutes of applying power, limits the **CompTest** to authorized personnel during system commissioning and periodic inspections.

How to Start the CompTest

WARNING:

Do not execute the CompTest until verifying that all systems connected to the NOVA-Sensor are properly configured to execute a test. Failure to do so may result in an unnecessary release of fire extinguishant or unnecessary dispatching of emergency personnel.

The CompTest must be started within 6 minutes of entering Protection Mode. The Safety-Code™ is entered into the NOVA-Sensor by using the **remote** RESET button, not the **MODE** switch which is on the NOVA-Sensor housing.

You begin the test in either of the two ways described below.

To begin the Test if Power has just been applied

To begin the test, wait at least 10 seconds after entering Protection Mode (but not more than 6 minutes). Then enter the **Safety-Code™** as described below.

To begin the test in an already operational system

It is not necessary to remove and reapply system power to initiate entry to **Protection Mode**. If the NOVA-Sensor is already powered up and in **Protection Mode**, press the **Remote RESET** Button and hold it in (active) for 20 to 30 seconds, then release it. This causes the sensor to begin the normal power up sequence (as if power had been cycled). Wait for 5 seconds after releasing **RESET**, then enter the **Safety-Code™** as described in the following section.

Entering the Safety-Code™

After following the previous instructions to insure that the NOVA-Sensor is ready to accept the Safety Code, press the Remote **RESET** Button for three (3) **ON** cycles (5 to 10 seconds each, separated by 5 to 10 second pauses). This will cause the sensor to execute the **CompTest™**. The sequence is summarized as follows:

<u>Action</u>	<u>Position:</u>	<u>Hold For Duration of:</u>
1	ON	5 Seconds
2	OFF	5 Seconds
3	ON	5 Seconds
4	OFF	5 Seconds
5	ON	5 Seconds
6	OFF	

Upon accepting the **Safety Code**, the NOVA-Sensor will pause for 10 seconds and begin the CompTest.

If an incorrect code is entered, the NOVA-Sensor will pause 15 seconds and initiate a normal reset sequence prior to returning to normal operation.

CompTest™ Operational Sequence

Upon receipt of the **Safety Code** within the first 6 minutes of entering Protection Mode, the following sequence is executed:

Fault Test

The following outputs are simultaneously toggled three (3) times, and are held in each state for approximately 2 seconds.

4-20 mA Loop	Alternates between 0 and 4 mA
Fault Relay	Toggles Open on Fault and Closed on Fault Outputs
LOW Alarm Relay	Inactive
HIGH Alarm Relay	Inactive

LOW Alarm Test

The following outputs are simultaneously toggled three (3) times, and are held in each state for approximately 2 seconds.

4-20 mA Loop	Alternates between 4 and 12 mA
Fault Relay	In Fault
LOW Alarm Relay	Toggles between active and inactive
HIGH Alarm Relay	Inactive

HIGH Alarm Test

The following outputs are simultaneously toggled three (3) times, and are held in each state for approximately 2 seconds.

4-20 mA Loop	Alternates between 4 and 20 mA
Fault Relay	In Fault
LOW Alarm Relay	Inactive
HIGH Alarm Relay	Toggles between active and inactive

Upon completion of the CompTest, the built-in self test (BIT) is executed and the system then returns to normal operation. If desired, the CompTest™ can be repeated by again entering the CompTest™ Security Code.

MAINTENANCE

The design of the electrochemical toxic gas cell used in the GT811 is such that it will work for many years, with minimal long-term output drift. In practice, normal slow degradation of the cell leads to a gradual loss of output over the life of the sensor. At times, the sensitivity may also increase, as well as decrease. There are many other factors that may cause the output signal to alter over the life of the sensor in normal use, some of which are: continuous exposure to the target gas, exposure to excessive concentrations of the target gas, physical damage and excessive changes in the concentration of electrolyte caused by long term exposure to humidity levels outside the rated working range.

Recalibration Schedule

Under normal operating conditions, SST gas detectors should be recalibrated every 90 days. However, the change in calibration over time is a function of how much “back-ground” gas is present during normal operation, and how often the detector is exposed to higher concentrations. When the gas sensor is initially installed, we recommend that the calibration be checked on a more frequent basis to determine how much the calibration is changing. To check, expose the detector to the same calibration gas as was used for the original calibration. Use the data taken over several tests to determine how often you should recalibrate the detector to keep the desired accuracy.

Sensor Replacement

After extended use, the sensing element may age to the point where it will no longer be able to calibrate properly. This will be indicated by a FAULT after performing a calibration. At this time, it is only necessary to replace the plug-in sensor element, then recalibrate. Replacement sensor elements are available from Safety Systems Technology. To replace the element, loosen the set screw on the front of the sensor head housing and unscrew the front cover.

- ! If the Model GT811 NOVA-Sensor will not recalibrate after a new sensor element is installed, it is necessary to perform a complete calibration of the sensor head assembly. Refer to instructions in the section headed “Recalibrating the Sensor Head” below.

Electronics Module Replacement

If the electronics module ever has to be replaced, the new module must be calibrated to the sensor head installed on the enclosure.

Spare Parts

The most common spare or replacement parts, available from SST are listed below.

Electronics Module P/N 40811-02

Plug-in Fuel Cell for Gas Sensor HeadP/N 20184-X
 Type 1, for sensors shipped in 1996 or earlier. Sensor housing has white plastic screen in front of sensor.

Plug-in Fuel Cell for Gas Sensor HeadP/N 10097-X
 Type 2, for sensors shipped from 1997 to September 2000.
 1.62 inch diameter cell for housing with porous metal filter in front of sensor.

Plug-in Fuel Cell for Gas Sensor Head P/N 20348-X
 Type 3, for sensors shipped October 2000 or later.
 1.25 inch diameter cell for housing with porous metal filter in front of sensor.

NOTE: X = 1 (H₂S), 2 (SO₂), 3 (CO), 4 (NH₃), 5 (Cl₂)

TROUBLESHOOTING

Wiring of the CHASSIS Terminal

The original wiring scheme of the field wiring in the terminal block on the bottom of the GC801 detector enclosure must be changed, if one or several of the following conditions apply:

- the voltage at the local conduit or EARTH/GND is currently differing more than 2V from the voltage at the 0V/RETURN wire of the power supply, or is expected to do so in the future,
- the power supply used for the GT811 must be floating with respect to EARTH/GND.

The reason for the change is that so called “transient voltage suppressor (TVS)” diodes used in the GT811 are internally connected to the CHASSIS terminal. This could cause problems in installations where the 0V/RETURN cable is supposed to be floating with respect to EARTH/GND and/or where abnormal voltages on the conduit or local EARTH/GND are expected. The problems in those cases could result from the TVS diodes providing a conducting current path between the CHASSIS and the EARTH/GND terminals.

The rewiring procedure will insulate the enclosure from the CHASSIS terminal and connect the CHASSIS terminal to the 0V/RET cable. The rewiring consists of the following steps:

- 1) Disconnect or shut off power to the GT811 detector(s).
- 2) Open the enclosure lid.
- 3) Carefully remove the electronics module from the enclosure.
- 4) Identify the revision of the electronics module. Look for the marking “REV” followed by a number on the topmost printed circuit board, in the clear space below the three digit numeric readout.
- 5) If the revision is 1.3 or later, no change is necessary. If it is 1.0, 1.1 or 1.2, proceed.
- 6) Remove the wire connecting the CHASSIS terminal and the internal grounding terminal in the enclosure.
- 7) Create a connection between the 24VRET and the CHASSIS terminals with a wire about 1" long. If the 24VRET terminal cannot be used due to too many wires, the connection can also go from CHASSIS to BUTTON B.
- 8) Recheck the wiring, carefully insert the electronics module and attach the lid of the enclosure.
- 9) Re-apply power and check for function. The units do not have to be recalibrated.

LOW-POWER VERSION

Operation of the Low-Power Version

The NOVA-Sensor is available with special firmware that reduces the amount of current drawn from the power supply during normal, non-alarm operation. This version is intended primarily for use at unmanned locations where operating power is supplied by an associated SST Solar Power Unit. In the low-power mode, the numerical readout and status LED's are completely blanked during normal operation.

NOTE: The low-power mode requires the NOVA-Sensor to be equipped with the low-power firmware.

With the five-position DIP switch the electronics module can be configured to operate in low-power mode. In this mode, the numerical display and the discrete LEDs ("HIGH", "LOW", "FAULT" etc.) will be dark unless one or more of the following condition(s) occurs:

- The MODE button is pressed briefly: This will result in a brief display of the current gas level, followed by the display of the LOW and HIGH setpoints and the reset of latched alarms.
- The MODE button is pressed for 5 to 10 seconds to initiate the calibration sequence: During the whole calibration sequence, the display will be on.
- The UP or DOWN buttons are pressed. The setpoints will be displayed. With no further operator inputs, the display will go back to dark.
- A gas concentration with a value equal to half the LOW alarm setpoint or more is detected. This will turn the display on and keep it on, as long as the gas level is above the threshold. Once the gas level falls below the threshold, the display returns to dark.
- An alarm is activated: The display will be switched on as soon as an alarm relay (LOW or HIGH) is activated and it will stay on with either relay in alarm.

RECALIBRATING THE SENSOR HEAD

Calibration Gas

Toxic Gas sensors require a small supply of oxygen to the counter and reference electrodes for correct operation. SST calibration gases are mixed with air for this reason. However, if air-balanced gas is not available, you can usually calibrate by applying pure gas. Sufficient oxygen will still be retained inside the cell for proper calibration.

Calibration Instructions

Calibration requires access to the potentiometers on the transmitter PC board located inside the GT810 housing. Unscrew the front cover from the sensor housing to locate these pots. Some housings have a setscrew in the front of the housing which must be loosened before the front cover can be unscrewed.

! If the sensor is installed in a hazardous area, be sure that no combustible gasses are present before the front cover is removed from the housing.

Once the front cover is removed, you must identify the type of transmitter pc board that is used in your detector. Use Figures 810-3 and 810-4 to identify your board. Note that the board in figure 810-3 has three adjustment pots, whereas the board in figure 810-4 has two pots.

Calibrating transmitter type shown in Figure 811-6

Potentiometers for routine span and zero adjustment are located on the transmitter circuit board inside the sensor housing (see figure 811-6).

The circuit board has an additional coarse gain potentiometer, which may also be used to calibrate the transmitter. However, this pot is factory adjusted, and resetting is not necessary for routine recalibration.

For calibration purposes, the signal may be monitored using either a standard milliammeter inserted into the 4-20 mA circuit, by connecting a millivolt meter to connector CN2 (which is across a 10 Ohm precision resistance on the circuit board), or by observing the reading on the associated gas detection module.

! If using CN2, accessory calibration cable, SST part no. 20185-1, is required.

To adjust the potentiometers a small screwdriver is required. Perform the following procedure to calibrate the sensor/transmitter combination:

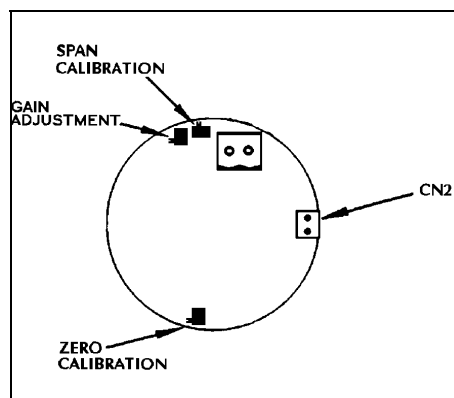

Fig. 811-6 Transmitter circuit board layout

1. Ensure the sensor is free from the gas being measured either by purging the sensor with pure air, or sealing the sensor from the atmosphere with the plastic plug shipped with the sensor.
2. Adjust the zero potentiometer until 0 ppm is shown in the measuring system. At 0 ppm the current in the system should be 4.0 mA, and there will be 40 mV across CN2 on the transmitter circuit board.
3. Apply a test gas whose known concentration is 50% of the desired full scale reading to the sensor. (For instance, apply 25 PPM gas to a sensor that is to be calibrated to read 0 to 50 PPM Toxic Gas.)
4. Wait for a stable reading to be obtained. This could require up to five minutes, although required time is usually much shorter.
5. Adjust the span potentiometer until the correct reading (in PPM) is shown in the measuring system, or until the current drawn by the sensor is exactly 12.0 mA. This can also be read as 0.12 volts across connector CN2.

Calibrating transmitter type shown in Figure 811-7

Potentiometers for routine span and zero adjustment are located on the transmitter circuit board inside the sensor housing (see figure 811-4).

For calibration purposes, the signal must be monitored using either a standard milliammeter inserted into the 4-20 mA circuit, or by observing the reading on the associated gas detection module. To adjust the potentiometers a small screwdriver is required. Perform the following procedure to calibrate the sensor/transmitter combination:

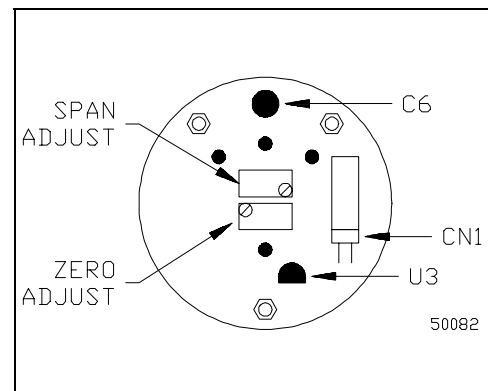

1. Ensure the sensor is free from the gas being measured either by purging the sensor with pure air, or sealing the sensor from the atmosphere with the plastic plug shipped with the sensor.
2. Adjust the zero potentiometer until 0 ppm is shown in the measuring system or 4.0 mA output is obtained. Turn the zero pot counter clockwise to increase the output.
3. Apply a test gas whose known concentration is 50% of the desired full scale reading to the sensor. (For instance, apply 25 PPM gas to a sensor that is to be calibrated to read 0 to 50 PPM Toxic Gas.)
4. Wait for a stable reading to be obtained. This could require up to five minutes, although required time is usually much shorter.
5. Adjust the span potentiometer until the correct reading (in PPM) is shown in the measuring system, or until the current drawn by the sensor is exactly 12.0 mA. Turn the span pot counter clockwise to increase the output.

Blank Page