

Standalone Detection Smoke Detectors 517 Series



The Edwards 517 Series Smoke Detectors are designed for multi-family, residential and institutional occupancies defined by NFPA 101, in compliance with UL 217 and NFPA 72.

The Edwards 517 Series provides a three position test feature that simulates actual smoke conditions. It also provides a maintenance indicator and makes the 100% testing requirement easy.

The temporal pattern evacuation tone is a standard feature.

It is designed for ceiling or wall mounting on a standard electrical box and can tandem wire up to 12 units (or 6 with relay) to form a system.

Features and Specifications

- Solid-state non-latching piezo horn
- Pulsing LED sensing chamber
- 3 position functional test switch
- Solid-state LED condition indicator
- Quick-disconnect wiring harness
- Mounting hardware adapts to standard junction boxes
- Dust cover
- 3 pulse temporal pattern evacuation sounding device
- 5-to-1 signal-to-noise ratio
- Operating temperature range: 40°F to 100°F (4.4°C to 37.8°C)

Ordering Information

Description	Cat. No.	Operating Voltage ¹	Aux. Contact 1 Form A, 1 Form C	Nominal Sensitivity	dB at 1m/10ft.	Isolated Heat 135°F	Contact Rating
Smoke Detector	517T	120V AC	—	2.5%	100/90	—	—
	517TH	120V AC	—	2.5%	100/90	Yes	—
	517TC	120V AC	Yes	2.5%	100/90	—	1 A @ 24V DC; 0.6 A @ 125V AC
Smoke Detector with 9V Battery Backup	517TB	120V AC	—	2.5%	100/90	—	—
	517THB	120V AC	—	2.5%	100/90	Yes	—
	517TCB	120V AC	Yes	2.5%	100/90	—	1 A @ 24V DC; 0.6 A @ 125V AC

¹AC voltage frequency is 60Hz.

Weights and Dimensions

Cat. No.	Approx. Shipping Weight (lb.)
517T	1.2
517TH	1.2
517TC	1.2
517TB	1.2
517THB	1.2
517TCB	1.3

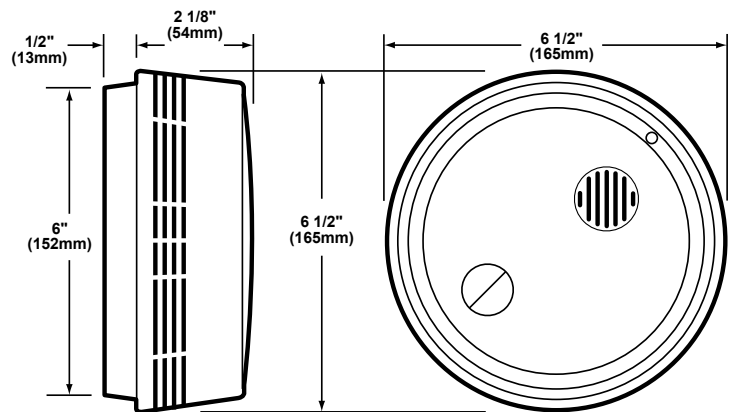

Ordering:
SAFETY SYSTEMS TECHNOLOGY
 23282 Mill Creek Drive, Suite 215
 Laguna Hills, CA 92653 USA
 Tel 1-949-583-1857
www.safetysys.com