

# Model GIR911 Infrared Carbon Dioxide NOVA-Sensor<sup>®</sup>



- **Unitized optical gas detector based on infrared operating principle**
- **Immune to poisoning**
- **Factory calibrated. No field calibration required**
- **No moving parts, no maintenance**
- **Calibration can be verified without declassifying the area**
- **Reading immune to wind velocity**
- **Suitable for on-shore or off-shore use**
- **Designed to UL, CSA, FM and CENELEC standards**
- **Analog and discrete outputs**
- **Digital display of gas concentration and sensor operating status**
- **Maintains calibration even after exposure to high gas concentrations**
- **Sensing elements do not deteriorate with age**

## THE DETECTOR

The GIR911 Infrared Carbon Dioxide NOVA-Sensor is a completely self-contained device that measures and displays the concentration of carbon dioxide accumulated in a protected area, performs local control functions, and optionally transmits this information to a central point.

## OPERATING PRINCIPLE

The GIR911 Infrared Carbon Dioxide NOVA-Sensor uses the proven non-dispersive infrared (NDIR) principle to detect and monitor the presence of gas. Using an infrared source lamp and an optical sensor with a narrow-band filter, an analysis of the optical absorption through the gas allows the concentration of the target gas to be determined. A second infrared sensor operating at a wavelength not affected by the target gas is used to eliminate effects resulting from ambient and physical variations. These include temperature changes, source and filter degradation and particle scattering.

## OPERATIONAL CHARACTERISTICS

The GIR911 is available in versions to operate in ranges from 2% to 100% CO<sub>2</sub> by volume with a resolution of less than 2% of full scale. Operating over 0-100% relative humidity and ambient temperatures between -10 °C and +50 °C, the GIR911 is particularly suitable for the reliable monitoring of lethal CO<sub>2</sub> levels in industrial safety applications.

Each GIR911 includes a high-reliability microprocessor based transmitter/controller in the associated explosion proof junction box. A digital readout is provided to continuously display operating status, fault diagnosis and

the actual concentration of gas present. The transmitter converts this reading to a standard 0-20 mA signal which may be connected to a suitable NOVA-5000 Gas Detection Module, or to any other device with a standard 0-20 mA input. Relays are provided for low alarm, high alarm and Fault. The low and high alarms activate at user selectable trip points. The Fault relay operates upon loss of power or internal failure of the unit. The relays are suitable for controlling local HVAC or other equipment shutdown.

The "One-Man" automatic performance verification sequence is initiated by depressing the pushbutton switch located on the side of the enclosure. During the verification process, the 0-20 mA and relay outputs are suppressed, and the detector automatically returns to normal operation when this process is complete.

The set points for the low and high alarms can be displayed by briefly touching the test button. The set points can be easily modified in the field, using the switches provided under the front cover.

During installation, the technician may optionally activate the built-in comprehensive test (CompTest™). During the CompTest, the GIR911's analog and relay outputs are activated, thus providing a complete operational check for the overall system.

The GIR911 is suitable for the most demanding applications. A large body mass insures excellent vibrational characteristics when used off-shore. Corrosion resistant materials permit use in harsh environments.



## ARCHITECTS AND ENGINEER'S SPECIFICATIONS

Carbon Dioxide gas sensing capability shall be provided by poison immune Infrared Carbon Dioxide detectors, contained in explosion-proof housings. The detector shall include control electronics which converts the measured gas concentration to the industry standard 0-20 mA signal, plus alarm and fault relay outputs. A continuously reading digital display shall be provided on the detector, capable of displaying detector status and the current gas concentration reading. A switch for verifying detector performance shall be provided. The verification shall be completely automatic, with data stored in non-volatile RAM in the detector, and shall not require any operator adjustment. Relay and analog outputs shall be inhibited during verification; however, it shall be possible to enable all outputs during verification when desired. The detector shall be suitable for on-shore or off-shore use, and the manufacturer's data shall so state. Safety Systems Technology Model GIR911 Infrared Carbon Dioxide NOVA-Sensor, or approved equivalent, shall be supplied.

## TECHNICAL SPECIFICATIONS

<b>Power Input:</b>	24 VDC, nominal 180 mA, 240 mA in alarm Will operate within specifications at any supply voltage between 16 and 32 VDC.
<b>Range:</b>	0-2%, 0-5%, 0-30% or 0-100% by volume Carbon Dioxide
<b>Warm-up Time:</b>	10 seconds operational, 20 minutes to specification
<b>Operating Temperature:</b>	+14°F to +122°F, -10°C to +50°C
<b>Signal Output:</b>	4 mA @ 0% CO <sub>2</sub> , 20 mA @ full scale CO <sub>2</sub>
<b>Resolution:</b>	2% of full scale
<b>Repeatability:</b>	Zero: ±0.5% of full scale Signal: ±1.0% of full scale
<b>Maintenance Interval:</b>	6 months for verification of performance only
<b>Relay Outputs:</b>	Low Alarm (latching or non-latching) High Alarm (latching) Malfunction (non-latching)
<b>Contact Rating:</b>	6 amps @ 28 VDC or 300 VAC Resistive 1/8 HP @ 120/240 VAC
<b>Analog Output:</b>	Standard 0-20 mA, self-powered source
<b>Size:</b>	6.7 inches x 11.9 inches x 5 inches deep Includes electronics housing and sensor housing. Conduit connections are 3/4 inch NPT thread
<b>Weight:</b>	6 pounds
<b>Hazardous Locations:</b>	Class I Division 1 Groups C,D

## ORDERING INFORMATION

Part No.	Description
911-84(**)	Model GIR911 Infrared Carbon Dioxide NOVA-Sensor with 0-20 mA and relay outputs. Copper free aluminum housing with epoxy finish.

\*\* Insert 2, 5, 30 or 100 (Sensor range in % volume)

## OPTIONAL ACCESSORIES

851-1	Rain Shield to protect sensor from rain or snow
852-1	Dust Cover with 40 micron filter to protect sensor from airborne dust
854-1	Duct Mounting Assembly Kit for extracting a sample from an air duct
866-1S	Test Verification Cup for applying test gas to sensor.

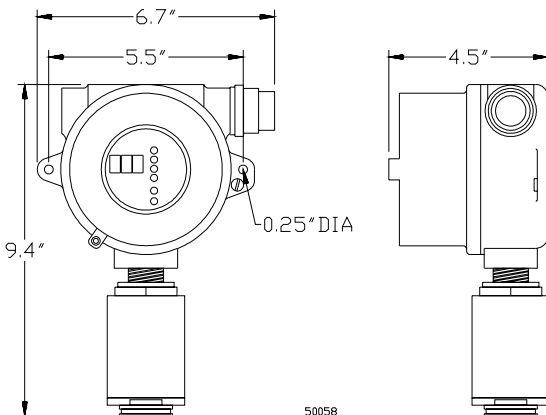

**SAFETY SYSTEMS TECHNOLOGY (NV), INC.**

23282 Mill Creek Drive, Suite 215, Laguna Hills, California 92653 USA  
Tel. 1-949-583-1857 Fax 1-949-340-6643 <http://www.safetysys.com>