

# DESIGN MANUAL

## Model GIR901 Infrared Combustible Gas NOVA-Sensor

70043

**The information in this document is applicable to  
sensors built on or after October, 2001**

---

The information and technical data disclosed by this document may be used and disseminated only for the purposes and to the extent specifically authorized by SAFETY SYSTEMS TECHNOLOGY in writing. Such information and technical data are proprietary to SAFETY SYSTEMS TECHNOLOGY and may not be used or disseminated except as provided in the foregoing sentence.

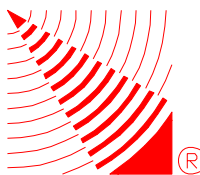

## SAFETY SYSTEMS TECHNOLOGY

23282 Mill Creek Drive, Suite 215  
Laguna Hills, California 92653 USA  
Tel 1-949-583-1857 Fax 1-949-340-6643  
[www.safetysys.com](http://www.safetysys.com)



# Quick Finder - Model GIR901 Infrared Combustible Gas NOVA-Sensor

---

QUICK START	901-1
Apply Power	901-1
Calibration	901-1
Alarm Setpoints	901-1
DIP Switch: Latch/No Latch Setting for LOW Alarm Output	901-1
DESCRIPTION	901-2
Principle of Operation	901-2
Detectable Gases	901-3
TECHNICAL SPECIFICATIONS	901-4
INSTALLATION	901-4
Installation Sequence	901-5
Mounting the enclosure	901-5
Wiring	901-6
Remote Sensor Version	901-7
DIP Switch settings	901-8
OPERATION	901-9
Power-Up	901-9
Changing the Setpoints	901-9
Calibration	901-10
Recalibration Schedule	901-12
NOVA-SENSOR OUTPUTS	901-12
0 to 20 mA Current Loop	901-12
Relay Outputs	901-12
FINAL OPERATIONAL CHECK-OUT (CompTest™)	901-13
How to Start the CompTest	901-13
Entering the Safety-Code™	901-14
CompTest™ Operational Sequence	901-14
MAINTENANCE	901-15
Replacing the Infrared Gas Detection Electronics	901-15
Digital Readout Module Replacement	901-16
Spare Parts	901-16
TROUBLESHOOTING	901-16
Drifting/Shifting display	901-16
Digital Display reads approximately minus 12%LEL	901-17



---

# MODEL GIR901 INFRARED COMBUSTIBLE GAS NOVA-SENSOR

---

---

## QUICK START

---

### Apply Power

---

A 30 second countdown is displayed, followed by a brief display of the firmware revision (e.g. "1.18"). Then the decimal points will flash while the unit displays "000" to confirm to the user that the NOVA-Sensor readout unit is properly functioning. This condition remains during the remainder of the 6 minute warm-up period for the IR sensor head. If "000" is not displayed within 6 minutes, and there is no background gas, the sensor requires initial calibration.

### Calibration

---

Wait at least 7 minutes after applying power before starting calibration. Calibration requires a sample of the hydrocarbon gas you want to detect, mixed with air to a concentration of 50% LEL (50% of the lower explosive limit of the gas). Insure that no background gas is present before initiating calibration. Press the large MODE button on the outside of the sensor housing for **at least 10 seconds**. The sensor flashes "000" while sampling the zero gas condition (10 seconds). Apply 50% test gas when the 000 stops flashing and the countdown from 30 to 0 begins. Then "CAL" will be flashed as the gas is sampled (may be as long as 3 minutes). When finished, the display reading will start to increase - remove the gas now. The sensor will reset its calibration to read 50%, and hold this reading for about 3 minutes. Normal operation begins once the displayed level is safely below the LOW alarm setpoint.

### Alarm Setpoints

---

To check the alarm setpoints without declassifying the area, simply press the large external MODE button for 1 second. Each alarm setting will be displayed for 5 seconds, along with its corresponding alarm LED (LOW or HIGH). To change setpoints, remove housing cover to access buttons labeled "UP" and "DOWN". Press the MODE button for 1 second, or press the UP/DOWN button. The LOW alarm LED will light as the setpoint is displayed. Use the UP/DOWN button to alter the value. After 5 seconds, the HIGH alarm LED and setpoint are displayed. Finally, after 5 seconds of button inactivity, the sensor will return to normal operation.

### DIP Switch: Latch/No Latch Setting for LOW Alarm Output

---

DIP switch position 4 (of the 4-position DIP) in the UP (Open) position selects LATCHING mode for the LOW alarm. Placing the switch DOWN (Closed) configures the LOW alarm as NON-LATCHING. Power must be cycled to "read" the new DIP setting.

- ! The HIGH alarm is always latched due to code requirements. DIP switch positions 1, 2 and 3 are set at the factory - DO NOT change setting! If you suspect that settings have been changed, reset per instructions on page 901-8.

## DESCRIPTION

---

The SST Model GIR901 Infrared Combustible Gas NOVA-Sensor is a completely self-contained device that measures and displays the concentration of gas accumulated in a protected area, performs local control functions, and transmits this information to a central control point.

### Principle of Operation

---

The GIR901 uses the absorption of hydrocarbons in the 3.3  $\mu\text{m}$  to 3.5  $\mu\text{m}$  range for the detection of any hydrocarbon gas. The absorption of the hydrocarbon compounds is a result of the oscillation of the H-C structure when exposed to energy. The GIR901 uses an incandescent lamp pulsed at 4 Hz in conjunction with two piezoelectric light sensors all contained in a stainless steel plug-in housing. In a patented configuration, the sensors are close to each other and are exposed to the direct light from the lamp, with no mirrors or other optical structures involved. In addition, almost no light is reflected by the walls of the housing thus eliminating all possible influences from wall contamination. The active sensor has an optical filter tuned to 3.4  $\mu\text{m}$ ; the reference sensor sees the wide-band infrared signal from the lamp.

The presence of hydrocarbons will decrease the signal to the active sensor significantly, while the signal to the reference sensor is almost unchanged. The electronics module contained in the GIR901 constantly measures the signals from both sensors, averages them to filter out noise and then calculates the ratio of the averaged active and reference signals. With a constant length of the optical axis, the relation between the active/reference ratio and the actual gas concentration is logarithmic. The length of the optical path yields an output for hydrocarbons that allows measurements with a resolution of 1%-2% of reading. The ratiometric principle makes it possible to eliminate almost all effects of temperature, aging, or fogging that would otherwise spoil the measurement. The optical operation principle has the following advantages:

- Readings independent of Oxygen, wind, etc.
- Readings NOT influenced by cross-sensitivity and poisoning
- No burn-out, saturation, shift or drift when the detector is exposed to high gas concentrations

Each SST NOVA-Sensor includes a high reliability microcontroller based transmitter/controller in the associated explosion proof junction box. A digital read-out is provided to continuously display operating status and the actual concentration of gas present in percentage of the Lower Explosive Limit (%LEL). The transmitter converts this reading to a standard 4-20 mA signal. This signal may be connected to a suitable SST NOVA-5000 Gas Detection Module, or to any other device with a standard 4-20 mA input. Connections between the transmitter and control device are normally made with 3 conductor cable [+24 VDC, 24 V return, 4-20 mA signal]. Dry contact relay outputs are provided for low alarm, high alarm, and fault conditions. The low and high relays operate at user adjustable alarm setpoints; the fault relay operates upon loss of power or internal failure of the unit. Relays are suitable for controlling local HVAC or equipment shutdown.

## Detectable Gases

As a rule, most members of the hydrocarbon family are indiscriminately detected by the GIR901. In contrast to the catalytic detector, long-chained hydrocarbons are detected with greater sensitivity than Methane and Ethane. The measuring principle is similarly applicable for other gases that chemically consist of dipole structures, such as CO<sub>2</sub> (with a 4.25 μm filter), and others, but NOT to mono-atomic or bi-atomic elements, such as H<sub>2</sub>, O<sub>2</sub>, CO, or He. See Tables 1 and 2.

**TABLE 1**  
**GIR901 Detectable gases**  
**with sensitivity relative to Methane**

Methanol	. . . . .	(10)
Propane	. . . . .	(9.3)
Butane	. . . . .	(8.6)
Ethane	. . . . .	(8.0)
Diesel	. . . . .	(7.5)
Ethanol	. . . . .	(7.1)
Hexane	. . . . .	(5.8)
Octane	. . . . .	(5.7)
Iso-propanol	. . . . .	(3.4)
Pentane	. . . . .	(2.5)
Methane	. . . . .	(1.0)
Acetone	. . . . .	(0.7)
Toluene	. . . . .	(0.5)
Ethene	. . . . .	(0.3)

For all gases with absorption lower than Methane, special versions of the GIR901 have to be used. The detector should always be calibrated with 50% LEL Methane.

**TABLE 2**  
**Other gases that can not be detected**

Carbon Disulfide	. . .	(no HC absorption)
Hydrogen	. . . . .	(no HC absorption)
Ammonia	. . . . .	(no HC absorption)
Ethene		
Acetylene	. . .	(HC absorption at 3.05 μm)
Benzene	. .	(HC absorption below 3.30 μm)
Carbon Monoxide	. .	(absorption at 4.7 μm)

## TECHNICAL SPECIFICATIONS

---

Power Supply . . . . .	.24 volts DC nominal, 180 mA standby, 240 mA when in alarm. Will operate within specifications at any supply voltage between 16 and 32 volts.
Range . . . . .	.0 to 100% LEL Hydrocarbon
Start-up time . . . . .	.6 minutes operational 20 minutes to specification
Response time . . . . .	.5 seconds typical. Time required for measured concentration to reach one half of the final concentration. Measured at 50% LEL.
Operating Temperature . . . . .	-.4 to +122° F. -20 to +50° C
Humidity . . . . .	.0-100% Relative Humidity
Signal Output . . . . .	.0.16 mA output per %LEL Automatically adjusted during calibration and during CompTest™
Resolution . . . . .	.2% LEL
Typical Combustible Gasses . . . . .	See Table 1
Relay Contact Ratings . . . . .	.6 amps @ 28 VDC resistive 6 amps @ 300 VAC resistive 1/8 HP @ 120/240 VAC
Analog Output . . . . .	Sensor will source 0 to 20 mA DC into a load of 600 ohms or less.

---

## INSTALLATION

---

A complete GIR901 unit consists of an explosion-proof housing with MODE button, Infrared gas sensor head, terminal blocks for field wiring and transparent lid used to observe the operational status of the numerical readout and LED's. The field wiring is connected to the terminal blocks inside the enclosure. The terminal blocks are accessible after removing the enclosure lid and the plug-in electronics module. The face plate on the electronics module carries various displays and controls. These are:

- Three-digit LED readout to display of gas concentration and status.
- Four round LED's, labeled "FAULT" (yellow), "HIGH" (red), "LOW" (red) and "CAL" (green). These LED's are used to signal alarms and operating modes.
- Two square pushbutton switches, labeled "UP" and "DOWN". These switches are accessible with a small screw driver or ball point pen and are used to adjust the alarm trip points of the unit.

## Installation Sequence

The electronics module contains parts that are delicate and potentially sensitive to electrostatic discharge (ESD). Remove the electronics module and store in the shipping box during installation. Reinstall the module just before system start-up, after all drilling and wiring is completed. The recommended installation procedure is as follows:

- Mount the enclosure
- Wire the power and signal cables
- Double check the field wiring for errors
- Set the DIP switches and suitcase jumpers on the electronics module
- Plug the electronics module into the housing
- Apply 24VDC power
- Set the alarm setpoints, if required
- Calibration and functional check out with CompTest, if required

## Mounting the enclosure

The dimensions of the GIR901 are shown in the figure below. It is preferable to attach the sensor to a wall or bracket, using bolts through the two mounting holes. However, these mountings may be omitted if the electrical conduit is sufficiently rigid to support the weight of the detector.

The location of the sensor is important. For lighter than air gasses, such as methane, the sensor should be located **above** the spot where a leak is likely. For heavier than air gasses, such as propane, locate the sensor **below** the expected leak. However, always locate the sensors at least one foot (30.5 cm) above the floor to prevent damage from water, dust, etc. Preferred orientation of the sensor is with the sensor head pointing down, as shown in figure 901-1. If necessary, it may be installed at an angle or horizontally.

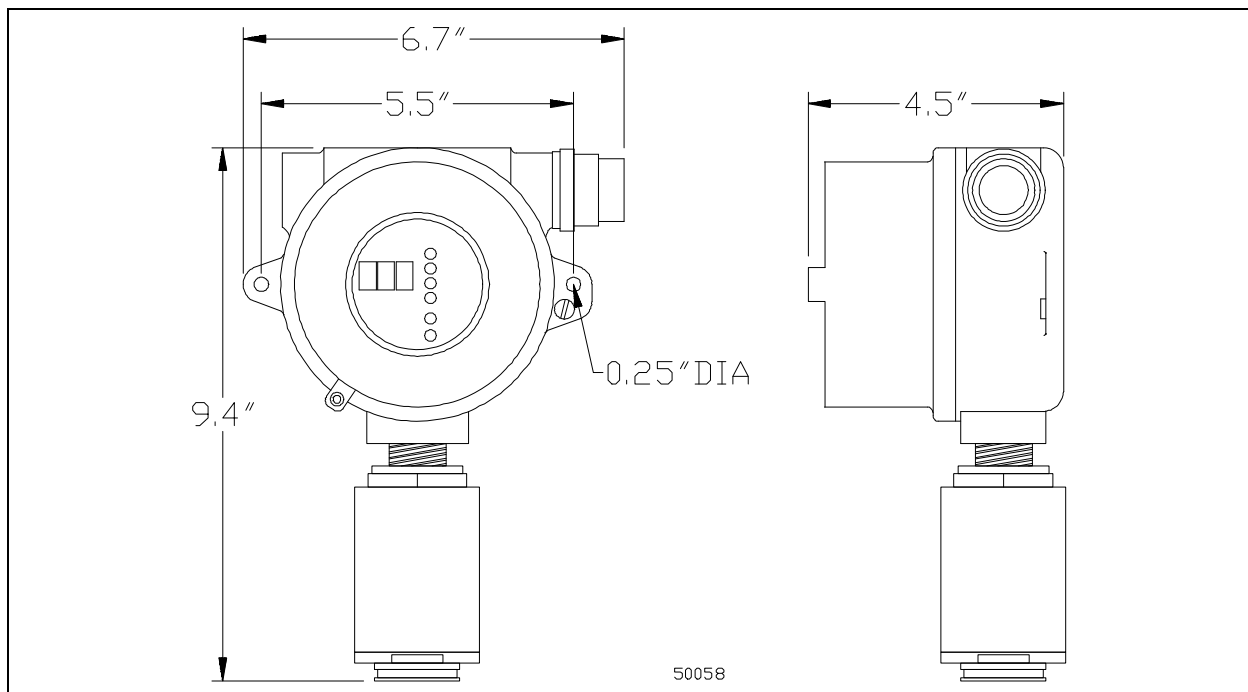

Figure 901-1 Mounting Dimensions

## Wiring

### Power input and Analog Signal Output

A typical installation is shown in figure 901-2. This setup uses three wires between the NOVA-Sensor and the associated control modules. These wires carry the 24 VDC operating power for the sensor, and transmit the 20 mA signal to the controls. The wires should be shielded or installed in metal conduit to prevent undesirable noise pickup. To wire the NOVA-Sensor, carefully remove the electronics module from the housing by pulling upward. Connect the three wires to the screw terminals in the housing as shown. Note that the "24VRET" wire is the common return for DC power and the 4-20 mA signal.

### MODE Pushbutton and Remote RESET

The external MODE pushbutton on the NOVA-Sensor housing can be used to clear any relays or alarms in the NOVA-Sensor which have been latched when activated. Pressing the button for less than 3 seconds (0.5 second minimum) will cause the latched relays to clear and the alarm setpoints to be momentarily displayed.

An optional external, remotely located, pushbutton can be wired to the terminal marked RESET. This should be a normally open contact, and should connect the reset terminal to 24VRET (common) to reset the sensor. The remote RESET button, when active for between 0.5 and 3 seconds will clear any latched relays.

### Relay Contacts

If the internal alarm and fault relay contacts are being used, additional wiring is required. The terminals for the three relays are marked as shown in figure 901-3. Connect wires to

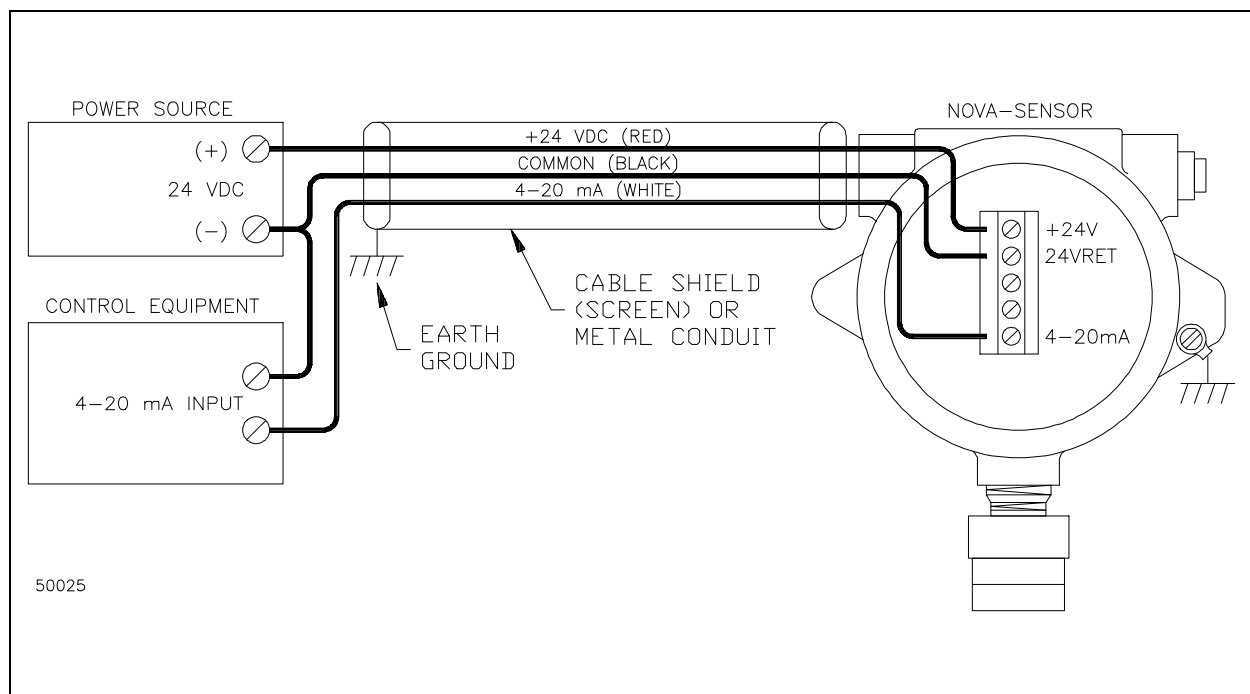

Figure 901-2 Typical Output Wiring

the respective terminals for any relays to be used. These are voltage-free “dry” contacts for connection to external equipment. Each of the three contacts may be independently set to be normally open or normally closed. As shipped, the low and high alarm relay contacts are normally open, and will close when an alarm condition is detected. As shipped, the fault contact will be closed under normal operating conditions, and will open upon loss of power or a fault in the NOVA-Sensor. The sense of the relay contacts can be changed by moving the programming jumper plugs on the bottom circuit board of the electronics module.

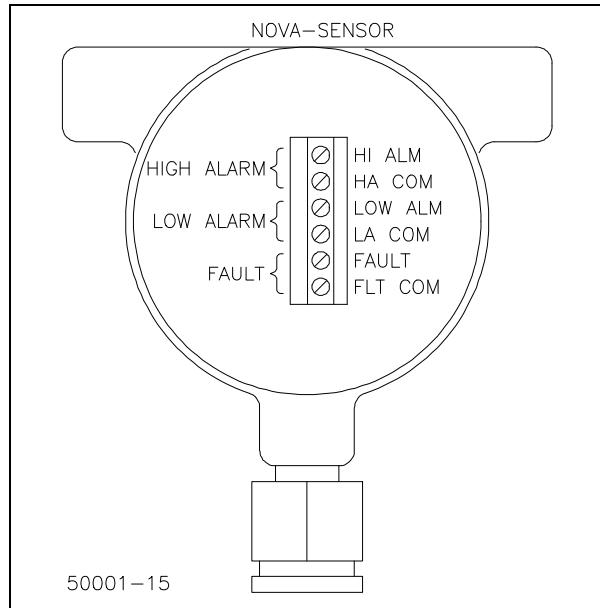

Figure 901-3 Relay Contact Connections

- To change the HIGH ALARM contact from normally open to normally closed, move the jumper on the pins marked HI ALM from the NO to the NC pins.
- To change the LOW ALARM contact from normally open to normally closed, move the jumper on the pins marked LO ALM from the NO to the NC pins.
- To change the FAULT contact from normally closed to normally open, move the jumper on the pins marked FAULT from the OF (Open on Fault) pins to the CF (Closed on Fault) pins.

! Relay contacts may require external protection to suppress transients. See figure 901-5 and the section [Relay Protection Circuitry](#) below.

### Remote Sensor Version

The remote sensor version is the same as a standard version, except that the sensor head is located away from the electronics enclosure. A SST Model GIR900 Infrared Combustible Gas Sensor is required for use with the remote GIR901 electronics package. A second 3/4 inch conduit connection is provided to connect the sensor electronics to the remotely located sensor head.

### Cable considerations

Four conductors are required between the Model GIR900 Sensor and the GIR901 electronics. These wires will be carrying a maximum of 20 mA at 24 volts DC to provide the required operating current to the Infrared Sensor transmitter. In general, the length of cable is not critical, as long as the total resistance of the cable does not exceed 650 ohms.

It is important to use shielded cable, or to install the wires in metallic conduit. Excessive noise picked up in the cables can make the display on the NOVA-Sensor jump between various values and can make calibration impossible. This is because the noise makes the NOVA-Sensor believe that the gas values are constantly changing. A constant gas value is the criteria for the end of a calibration.

- If shielded cable is used, it must be grounded only at the GND terminal in the GIR901 electronics enclosure. The GIR901 enclosure must also be properly grounded. Insulate the shield at the sensor end so that it will not be grounded.
- Avoid running the cable close to high-powered cables or equipment or close to radio transmitters or antennas.

### Cable Color Codes

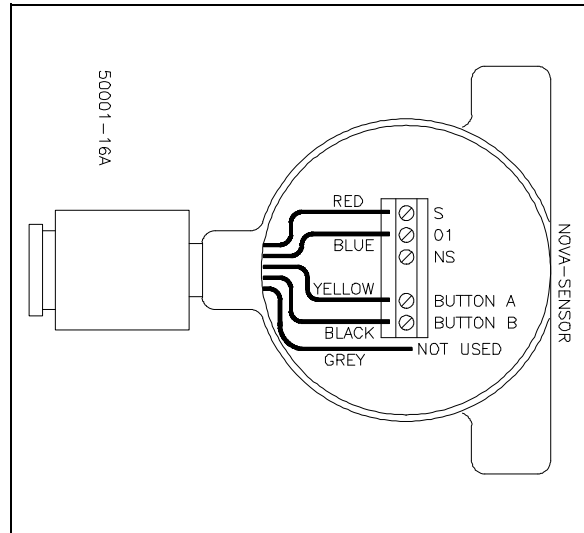

Figure 901-4 Sensor head color codes

The GIR900 infrared gas sensor head is supplied with five color coded wires which connect to the terminals in the GIR901 electronics package. See figure 901-4 for hookup. Be extremely careful to connect each lead to the proper terminal. Interchanging two wires will almost always result in a burned out sensor.

### DIP Switch settings

One or two piano-type DIP switches are visible from the side of the electronics module. These switches set the electronics for the type of sensor head installed, and set the operating mode.

#### Four-Position DIP Switch

- ! **WARNING: Switches 1, 2 and 3 are preset at the factory to DOWN/UP/UP for switch positions 1, 2 and 3 respectively. DO NOT ADJUST these switches! Serious damage to the sensor or electronics module may occur if these switches are incorrectly set.**

Switch position 4 selects the LOW alarm relay as latching or non-latching. The UP position selects LATCHING mode: once activated, the low alarm relay will remain in the alarm state until the NOVA-Sensor is manually reset with the MODE button or the remote reset signal. The DOWN position selects NON-LATCHING mode: after activation, the low alarm relay will return to the normal state as soon as the gas concentration sensed is less than the low alarm set point. The HIGH alarm is always latched to conform to code requirements.

#### Five-Position DIP Switch

This switch is provided on “low-power” models only. All five positions on this DIP switch must be in the UP position to select the low-power mode. Any other setting will cause the NOVA-Sensor to operate in standard power mode.

---

## OPERATION

---

### Power-Up

---

When power is first applied, the microcontroller executes a built-in test (BIT), during which various internal components and parameters are checked. During the BIT, the indicator lights will be flashing. Upon successful completion of the BIT, the NOVA-Sensor begins a 30 second countdown period to allow time for proper temperature stabilization. The countdown is displayed on the digital read-out. At the end of the countdown, the NOVA-Sensor displays its firmware revision code (e.g. "1.18"). The unit is now waiting for the IR sensor head to warm up sufficiently to provide stable readings.

- ! Do not depress the large MODE button on the side of the enclosure during this initial warm up period. Depressing the button during this time erases the previously saved calibration data, and will make recalibration more difficult.

During warm up and normal operation, the digital read-out displays "000". As a further verification that the unit is operating properly, the decimal points on the digital read-out slowly rotate from one digit to the next while displaying "000"). Three to five minutes after the power was first applied, the NOVA-Sensor is operating at the factory default calibration and alarm setpoints. Calibration data and alarm setpoints are maintained in non-volatile memory to insure proper operation should the +24 VDC supply be temporarily interrupted. No special care is required to maintain this memory.

### Changing the Setpoints

---

Setpoints for HIGH alarm and LOW alarm are available for user modification. Factory defaults for the HIGH and LOW alarms are 50% LEL and 20% LEL.

- ! Setpoints will "roll over" to zero at 100% LEL.  
Do not select setpoints below 5% LEL!

To adjust either the HIGH or LOW setpoints, momentarily press either the UP or DOWN pushbutton on the face of the electronics module, using a small screwdriver or ballpoint pen. At this point, the LOW alarm LED will turn on, and the LOW alarm setpoint will be displayed. The user has 5 seconds to begin to adjust the LOW alarm setpoint by pressing the UP or DOWN button. Once the microcontroller has detected 5 seconds of inactivity (no button press), the unit will light the HIGH alarm LED and display the previously stored setpoint value. The operator will again have 5 seconds to begin adjusting the HIGH alarm setpoint. After an additional 5 seconds of inactivity, the NOVA-Sensor will store the new values in non-volatile memory and return to normal operation.

## Calibration

---

The GIR901 NOVA-Sensor is pre-calibrated at the factory for a specific target gas. It cannot be recalibrated to another hydrocarbon gas unless you replace the transmitter module in the gas sensor head with a new module. See the markings on the outside of the sensor head to determine which gas is required for calibration. A new calibration will take care of changes in detector performance and drift. During the calibration procedure, clean air as well as gas with a defined percentage of combustible gas are applied to the detector in order to provide the NOVA-Sensor with reference points needed to measure gas levels.

The presence of “clean” air, i.e. air without any combustible components, is absolutely necessary to provide the electronics module with a reference point for 0% LEL gas concentration. In locations where clean air cannot be assured, you may need to “purge” the sensor with clean air from a gas bottle before starting the calibration procedure. **DO NOT USE nitrogen to purge the sensor, false readings may result!**

The calibration can be performed by one person, and with the NOVA-Sensor operating in the classified area. No manual adjustments are required for calibration.

! NOTE: The sensor must be calibrated using the gas that the sensor is expected to detect at a concentration of exactly 50% of the lower explosive limit (LEL) of the gas.

! **The GIR901 must “warm up” for at least 7 minutes after power is first applied before calibrating. Calibration will be more accurate if you can wait 30 minutes before starting. Do not push the MODE button on the housing during the first 10 seconds of warm up, or previous calibration data will be erased from the non-volatile memory.**

The calibration procedure is as follows:

1) Depress the large mode button on the side of the NOVA-Sensor enclosure and hold it depressed for **a full ten seconds**. The NOVA-Sensor acknowledges by lighting the three dots on the numerical readout.

! **It is important to hold for 10 seconds to insure that the electronics in both the IR sensor head and in the digital readout module are put into the calibration mode.**

2) Once the MODE button is released, the numerical readout will flash “000” and “...” for about ten seconds. During this time, the NOVA-Sensor is storing the zero reference point, based on clean air applied to the sensor.

3) The NOVA-Sensor then begins a 15-second count-down, during which it displays the numbers “030” through “000” on the read-out. During this time, the NOVA-Sensor is simply waiting for the calibration gas to be applied and conveyed to the sensor.

! In order to save gas it is recommended to apply calibration gas as soon as the 15-second count-down begins. Up to 3 minutes delay is tolerable for cases where the sensor head is at a remote location and the calibration gas must be applied through a long pipe.

4) At this point, only the gas sensor head is being calibrated. During head calibration, the output of the head is held at the “zero” level, so the digital read-out continues to alternate between “**CAL**” and a small number that represents the zero gas concentration, relative to the previous calibration. Additionally the CAL LED blinks. This condition can last for up to 5 minutes.

- ! **If the digital readout begins to read the gas concentration at this point, rather than remaining near zero, the MODE pushbutton was not held long enough in step 1) above.** In this case, remove gas, wait for sensor to return to normal operation, then start again at step 1.

5) When the gas sensor head is successfully calibrated, the head output will be held constant at the new calibration level, and the readout will start to count up from the previous zero setting to the new calibration.

- ! **IMPORTANT:** The calibration gas should be removed from the sensor head as soon as the display begins to count up. Leaving the gas on at this point will result in wasted test gas.

6) When the read-out displays “**050**”, the new calibration reference for 50% LEL gas is stored. At the same time the CAL LED changes from blinking to steady.

7) The 50% LEL reading will be held for approximately 3 minutes, after which the read-out will decrease. Once the read-out is below the LOW alarm setpoint or at zero, the NOVA-Sensor returns to normal operation and the CAL LED is switched off. The microcontroller in the NOVA-Sensor automatically stores the calibration in its internal non-volatile memory for use in subsequent measurements.

During the calibration process, the 4-20 mA output is set to 2 mA and the relay outputs are suppressed. The NOVA-Sensor automatically returns to normal operation when the calibration is complete.

### **Failed or Incomplete Calibrations**

If the calibration procedure is aborted (e.g. by not applying calibration gas), the NOVA-Sensor will return to normal operation after a time-out period of 3 1/2 minutes. In this case the NOVA-Sensor will use its original, pre-calibration data. Turning the power off will also abort the calibration procedure. Common causes for incomplete calibration are:

1) Calibration gas runs out during calibration. In this case, wait for the NOVA-Sensor to return to normal operation and repeat procedure with a fresh calibration gas bottle.

2) Calibration gas concentration too LOW. The NOVA-Sensor will not accept calibration gas with concentration below 20% LEL. Using gas cylinders with low pressure will often be interpreted by the NOVA-Sensor as low gas concentrations. In this case, wait for the NOVA-Sensor to return to normal operation and repeat procedure with fresh calibration gas bottle.

3) Gas applied at wrong time. Gas applied during step 2 above (too early, during clean air sampling) will result in negative displays and inaccurate readings. If the gas is applied too late (which may occur due to the pipe length when remote sensors are used) it may not reach significant levels before the 3 1/2 minute time-out and thus abort the calibration procedure.

### Recalibration Schedule

---

Due to the extreme stability of the infrared gas sensor, recalibration is rarely required. However, SST recommends that test gas should be applied to the sensors every 90 days to verify proper sensor operation. Before testing, do a visual inspection to check for contamination of the sintered metal sensor cover, loose parts, etc. *Be sure to deactivate any connected equipment before applying test gas to the detector to prevent false alarms!*

---

## NOVA-SENSOR OUTPUTS

---

The characteristics of the various NOVA-Sensor outputs are explained in more detail in the following sections.

### 0 to 20 mA Current Loop

---

The current loop output is normally between 4 and 20 mA, and is a direct linear read-out of gas concentration. Output is 4 mA when no gas being detected. Output is 20 mA when the full scale gas concentration of gas (100% LEL) is being detected. The 0 to 20 mA circuitry will reliably and accurately (.002% typical nonlinearity) drive a load resistance of between 100 and 600 ohms. The 0 to 20 mA circuitry is self calibrating and does not require adjustment. The Safety Systems “**Trim-Not**” technology eliminates the requirement for field adjustable trim-pots.

Should a malfunction occur in the sensor or the current loop wiring, the output will, of course, be 0 mA. Before any calibration has been performed, the output will be 2 mA.

During the start-up time delay and during routine calibrations, the output remains at 4 mA. During normal operation, the loop current can be determined with the following formula:

$$I \text{ (in mA)} = 4 + 0.16 \times \%LEL$$

### Relay Outputs

---

The NOVA-Sensor includes three (3) relays for connection to external devices. The LOW alarm and HIGH alarm relays operated when the concentration of gas measured exceeds the respective setpoints. The fault relay transfers on detection of a fault in the NOVA-Sensor.

Each relay can provide either a normally open or normally closed dry contact output. The **LOW alarm** relay can be set as either **latching** or **non-latching** - see section “DIP Switch Settings”. The **fault relay** is always **non-latching** (self clearing).

### Relay Protection Circuitry

Heavy duty relay contacts are provided in the NOVA-Sensor. These contacts are rated for resistive loads. If used for switching inductive loads, such as relay coils, lamps, beacons, etc., you must provide suitable suppression at the load. This will prevent burning the relay contacts, and also suppress harmful transients which can affect the operation of electronic equipment. See figure 901-5 for the recommended protection for DC and AC loads.

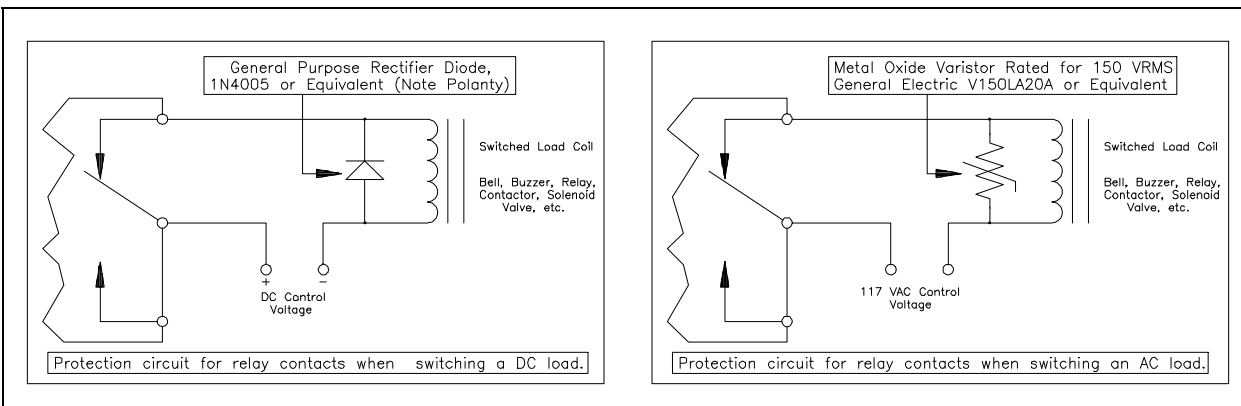

Figure 901-5 Relay Contact Protection Scheme

## FINAL OPERATIONAL CHECK-OUT (CompTest™)

Once the NOVA-Sensor has entered normal operation, a final comprehensive output test (CompTest) of all detector inputs and outputs is available. The CompTest is a way to verify that the NOVA-Sensor relay outputs and 0 to 20 mA current loop are correctly operating. It can also be used to determine if the peripheral equipment is properly connected to the NOVA-Sensor.

The CompTest ramps the 0 to 20 mA current loop through each of its assigned values while changing the relay outputs as well. Each output state for the 0 to 20 mA loop and each of the three relays is held for about 2 seconds and repeated 3 times. The test lasts for approximately 1 minute. At the completion of the test, the built-in test (BIT) is executed and the unit is returned to normal PROTECTIVE MODE operation.

### What keeps the CompTest from occurring during operation or by mistake?

Because the **CompTest** exercises all outputs, including **LOW ALARM** and **HIGH ALARM** states, there are several built-in safe guards against its inadvertent use. *The button located on the side of the NOVA-Sensor (the Mode button) will not initiate a CompTest.* The remote reset input on the NOVA-Sensor is used to initiate the test, based on a coded sequence of ON's and OFF's. Upon receiving the proper coded input (the CompTest Safety Code), the NOVA-Sensor begins the test. The NOVA-Sensor will only start the output tests if the proper Safety Code is entered. For additional security against inadvertent use, the Safety Code can only be entered **during the first 6 minutes** after the NOVA-Sensor has been returned to normal operation. Requiring a special **Safety Code** to be entered within 6 minutes of applying power limits the **CompTest** to authorized personnel during system commissioning and periodic inspections.

### How to Start the CompTest

- ! **WARNING:** Do not execute the CompTest until verifying that all systems connected to the NOVA-Sensor are properly configured to execute a test.
- Failure to do so may result in an unnecessary release of fire extinguishant or unnecessary dispatching of emergency personnel.

The CompTest must be started within 6 minutes of entering Protection Mode. The Safety-Code™ is entered into the NOVA-Sensor by using the remote Reset button, not the MODE switch which is on the NOVA-Sensor housing.

You begin the test in either of the two ways described below.

**To begin the Test if Power has just been applied**

To begin the test wait at least 3 minutes after power up (but not more than 6 minutes). Then enter the **Safety-Code™** as described below.

**To begin the test in an already operational system**

It is not necessary to remove and reapply system power to initiate entry to **Protection Mode**. If the NOVA-Sensor is already powered up and in **Protection Mode**, press the Sensor **Reset** Button and hold it in (active) for 20 to 30 seconds, then release it. This causes the sensor to begin the normal power up sequence (as if power had been cycled). Wait for 5 seconds after releasing **Reset**, then enter the **Safety-Code** as described in the following section.

**Entering the Safety-Code™**

---

After following the previous instructions to insure that the NOVA-Sensor is ready to accept the Safety Code, press the **Reset** Button for three (3) **ON** cycles (5 to 10 seconds each, separated by 5 to 10 second pauses). This will cause the sensor to execute the **CompTest™**. The sequence is summarized as follows:

Action	Position:	Hold For Duration of:
1	<b>ON</b>	5 Seconds
2	OFF	5 Seconds
3	<b>ON</b>	5 Seconds
4	OFF	5 Seconds
5	<b>ON</b>	5 Seconds
6	OFF	

Upon accepting the **Safety Code**, the NOVA-Sensor will pause for 10 seconds and begin the CompTest.

If an incorrect code is entered, the NOVA-Sensor will pause 15 seconds and initiate a normal reset sequence prior to returning to normal operation.

**CompTest™ Operational Sequence**

---

Upon receipt of the **Safety Code** within the first 6 minutes of entering Protection Mode, the following sequence is executed:

### Fault Test

The following outputs are simultaneously toggled three (3) times, and are held in each state for approximately 2 seconds.

<b>0 to 20 mA Loop</b>	Alternates between 0 and 4 mA
<b>Fault Relay</b>	Toggles between Fault and no fault
<b>LOW alarm relay</b>	Inactive
<b>HIGH alarm relay</b>	Inactive

### LOW Alarm Test

The following outputs are simultaneously toggled three (3) times, and are held in each state for approximately 2 seconds.

<b>0 to 20 mA Loop</b>	Alternates between 4 and 12 mA
<b>Fault Relay</b>	In Fault
<b>LOW alarm Relay</b>	Toggles between active and inactive
<b>HIGH alarm</b>	Inactive

### HIGH Alarm Test

The following outputs are simultaneously toggled three (3) times, and are held in each state for approximately 2 seconds.

<b>0 to 20 mA Loop</b>	Alternates between 4 and 20 mA
<b>Fault Relay</b>	In Fault
<b>LOW alarm Relay</b>	Inactive
<b>HIGH alarm Relay</b>	Toggles between active and inactive

Upon completion of the CompTest, the built-in test (BIT) is executed and the system then returns to normal operation. If desired, the output test can be repeated by again entering the CompTest security code.

---

## MAINTENANCE

---

The GIR901 is easy to service. Most service activities will require the lid of the detector base or the enclosure of the GIR900 sensor head to be opened.



**CAUTION: Before opening lids or enclosures, the area must be free of any combustible gasses!**

### Replacing the Infrared Gas Detection Electronics

---

After many years of use, the infrared source lamp in the detection electronics may fail. In this failure mode, the digital readout will display approximately “-12”, and there will be no response when gas is applied to the gas detector. To replace, follow this procedure:

1) Remove the window cover from the NOVA-Sensor readout module and unplug the electronics module. This will disconnect the power to the IR sensor head.

- 2) Remove the sintered metal cover from the sensor head by loosening the set screw and then turning the cover counter-clockwise.
- 3) The infrared source lamp is contained inside the plug-in gas detection element visible on the PC board assembly. Grasp the detection element and lift it (along with the PC board assembly) from the housing. Replace with a new Infrared Transmitter Module available from SST.
- 4) Line up the two connectors on the bottom of the infrared transmitter module with the mates inside the housing and plug in. Replace the sensor head cover and tighten set screw.
- 5) Replace the digital readout electronics into the housing.

**! Do not depress the MODE button on the side of the enclosure during this initial warm up period. Depressing the button during this time erases previously saved calibration data, and will make recalibration more difficult.**

- 6) Complete the calibration of the new electronics, following all instructions listed under **Calibration** in this manual.

### Digital Readout Module Replacement

---

If the electronics module with digital readout ever has to be replaced, the new module must be calibrated to the sensor head installed on the enclosure.

### Spare Parts

---

Installations which require on-site spare parts inventory should order the following part numbers:

40901-02	. . . . .	Combustible Electronics Module with digital readout
40901-35-2	. . . . .	Plug-in Transmitter Module, Methane
40901-35-3	. . . . .	Plug-in Transmitter Module, Propane
40901-35-5	. . . . .	Plug-in Transmitter Module, Butane
40901-35-7	. . . . .	Plug-in Transmitter Module, Ethane
40901-35-8	. . . . .	Plug-in Transmitter Module, Pentane

---

## TROUBLESHOOTING

---

### Drifting/Shifting display

---

Drifting or shifting or otherwise unexplainable display (i.e. display of negative or positive gas values with no apparent cause) on GIR901 Infrared NOVA-Sensors can have the following causes:

- 1) Bad contact between electronics module and terminal blocks in enclosure. This effect is noticeable when pressing on the installed electronics module from the top or when twisting it.
- 2) Loosened or contaminated suitcase jumper on relay board of electronics module.

3) If an electronics module that is not calibrated or that had been calibrated with a different sensor (in a different enclosure) is plugged into an enclosure, positive or negative gas values may be displayed. In this case, make sure that alarming devices are disconnected before plugging in, and that the unit is calibrated before re-connecting the alarming devices.

Bad contacts may be fixed with the following procedure:

- 1) Unplug the electronics module and clean the two green connectors on the back of the electronics module with a brush and alcohol. Clean the corresponding contacts on the green terminal blocks in the enclosure in the same way.
- 2) Unplug the two suitcase jumpers located on the headers labeled "TOX" on the lowermost printed circuit board of the electronics module stack (note jumper position for later re-insertion). Clean contacts inside of jumper and on pin header. If possible, insert a new clean suitcase jumper with gold plated contacts. Alternatively, the two header contacts at "TOX" may be connected by wire-wrap or soldering. When soldering, be careful to apply little heat in order not to loosen the pin strip header from the printed circuit board.

---

**Display reads approximately minus 12%LEL**

---

This is caused when the NOVA-Sensor has no calibration data saved in non-volatile memory. Perform a complete calibration per instructions in this manual.

Blank Page